

Evaluation of Magnetic Characteristics of Soft Magnetic Powder Cores under Mechanical Stress

Kohei YOSHIKAWA*, Yukinori YAMADA, Shinichiro YAMAMOTO, Yasushi MOCHIDA, Shingo OHASHI, Yuka FUKUNAGA, Takanori SAWAI, Koji FUJIWARA and Yoshiyuki ISHIHARA

In electromagnetic equipment, laminated steel sheets and soft magnetic powder core are used as the magnetic core in electromagnetic circuit. Soft magnetic powder core has three advantages over conventional magnetic core, which are three-dimensional formability, three-dimensional flux capability and material recyclability. Due to these advantages, soft magnetic powder core is being expected to be used as a new soft magnetic material in recent studies. Driving performance and efficiency in electromagnetic equipment are affected by the magnetic properties of core materials. In the manufacturing process of motors, mechanical stress caused by shrink fit and caulking is applied onto motor core. The magnetic properties of core are degraded by mechanical stress. In this study, the effect of mechanical stress on the magnetic properties of motor core is examined in detail.

1. Introduction

A soft magnetic powder core is fabricated by pressure compacting magnetic particles that have electric insulating layers on the surface. This type of magnetic core enables three-dimensional magnetic circuits and complex shapes to be formed, and thus it is anticipated that soft magnetic powder cores will be used for many applications such as motors and inductors.

The efficiency and performance of an electromagnetic component are substantially affected by the magnetic characteristics of the soft magnetic material used as the core. In the fabrication of electromagnetic components, the core is subjected to mechanical stresses during machining processes such as cutting, shaving and surface treatment and assembly processes such as shrink fitting or caulking into a housing. Compressive and tensile stresses are included in these mechanical stresses. The magnetic characteristics of cores are degraded by these mechanical stresses, and thus it is important to clearly evaluate the relationship between the magnetic characteristics and the applied stresses. However in many cases, the electromagnetic components have been designed based on the magnetic characteristics of soft magnetic materials that were measured without any applied stress. Several groups have investigated the magnetic characteristics of a single electromagnetic steel sheet under compression or tensile stress ⁽¹⁾⁻⁽³⁾.

In this study, the magnetic characteristics of soft magnetic powder cores were evaluated as following: (1) simulation of applied stresses on the core after assembling a motor; (2) development of an evaluation method for magnetic characteristics under stress for solid rectangular test pieces; and (3) evaluation of the relationship between the magnetic characteristics and the applied stress. In the case of soft magnetic powder cores, the magnetic characteristics are affected by the density of the compacted body and the particle size of the soft magnetic powder. This study investigated the effects of the density of the compacted body and the particle size on the mag-

netic characteristics under stress. Additionally the magnetic characteristics of laminated steel sheets were evaluated to provide a comparison with soft magnetic powder cores.

2. Stress Distribution in the Motor Structure

Generally, the stator of a motor is assembled into its housing under mechanical stress. Before evaluating the relationship between the stress and the magnetic characteristics, a simulation was carried out on the stress distribution in a motor assembled by a shrink fitting technique. Although the stress distribution depends on the assembly conditions, the results of the simulation and measurements revealed that the assembly process generates a distribution of stresses on the motor core, including tensile stresses from 0 to 50 MPa and compressive stresses from 0 to 150 MPa. This study presents the results of a simulation of the stress distribution in a simple motor model analyzed using MSC Nastran.

Figure 1 shows a shrink fit simulation model comprising a stator 119 mm in outside diameter and a ring with 0.3 mm of diametrical interference. **Figure 2** shows the simulation results. Circumferential compressive

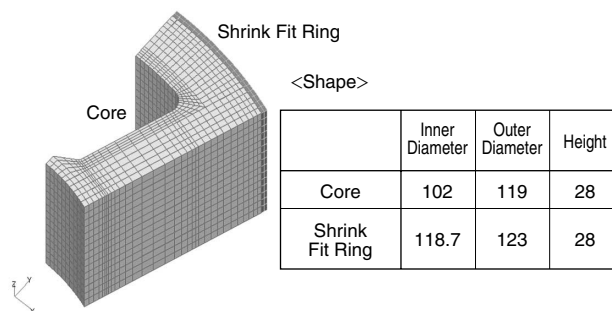

Fig. 1. Shrink-fit stress analysis model of simple motor

stresses of 100 MPa were found in a large part of the yoke section of the motor (“a” in the figure), while in the inner part of the yoke section (“b” in the figure), higher circumferential compressive stresses of 125 MPa were found, as shown in Fig. 2. By contrast, 30 MPa radial tensile stresses were found in the part close to the boundary of the yoke and the teeth (“c” in the figure). The simulation results suggest that the stresses generated by the shrink fit were circumferential compressive stresses in the yoke section and radial tensile stresses in the teeth section. Furthermore, the principal radial motor has circumferential flux in the yoke section and radial flux in the teeth section. These findings suggested that the flux directions were approximately the same as the direction of the stresses resulting from the shrink fit.

It is known that the magnetic characteristics of electromagnetic steel sheet are degraded by compressive stresses⁽¹⁾⁻⁽³⁾. Thus this study focused on compressive stresses in the yoke section. The magnetic characteristics of a soft magnetic powder core under stress were evaluated under conditions in which the stress direction was aligned with the flux direction.

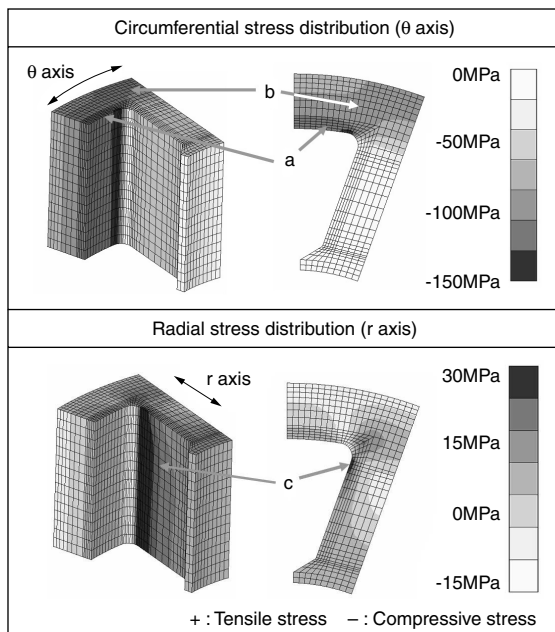

Fig. 2. Stress simulation results

3. Development of a Method for Evaluating Magnetic Characteristics of Soft Magnetic Powder Core under Stress

3-1 Test samples

Being similar to other magnetic materials, the magnetic characteristics of soft magnetic powder core are greatly influenced by cutting and other machining processes. In this study, a rectangular solid sample prepared by compaction was used in order to minimize the effects caused by machining. Figure 3 shows the directions of magnetic flux and applied stress in the test piece.

Table 1 shows the properties of the test samples. The magnetic characteristics of the soft magnetic powder core were evaluated by using these samples. The magnetic characteristics of two types of laminated steel sheets commonly used for motors and inductors were evaluated to provide a comparison with soft magnetic powder cores.

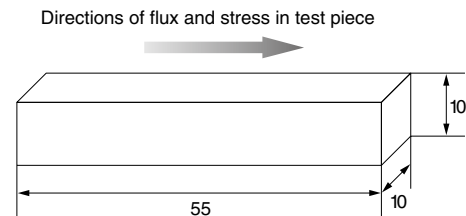

Fig. 3. Directions of flux and stress in test piece

Table 1. Properties of test samples

Sample Name	Average Particle Size [μm]	Density of Sample [Mg/m ³]
Sample #1	250	7.57
Sample #2	250	7.45
Sample #3	250	7.30
Sample #4	100	7.42
Sample #5	50	7.43

3-2 Apparatus to apply stress

Stresses were applied parallel to the longitudinal direction of the sample. Compressive stresses were applied using a hydraulic cylinder at one end of the sample with the other end being fixed, as shown in Fig. 4. Tensile stresses were applied by bonding tension jigs to both ends of the sample.

3-3 Construction of the apparatus to evaluate the magnetic characteristics

A schematic diagram of the apparatus used to evaluate the magnetic characteristics is shown in Fig. 4. A closed magnetic path is needed to evaluate the magnetic characteristics, and so the sample was sandwiched between cut wound cores (the double yoke method). The double yoke method was adopted in order to achieve a uniform flux in the test piece⁽⁴⁾.

The 25 mm section at the center of the sample was used to evaluate the magnetic characteristics. Covering the whole measurement area, a single layer pick-up coil of 20 turns was formed to measure the induced voltages. This coil is referred to as coil B in the following. An exciting coil was formed over coil B, comprising two evenly-wound 25-turn layers. Under these conditions, an electric current was supplied to the exciting coil. The induced voltage in coil B resulting from the current applied to the exciting coil was measured, and the flux in the sample was calculated from the measured voltage.

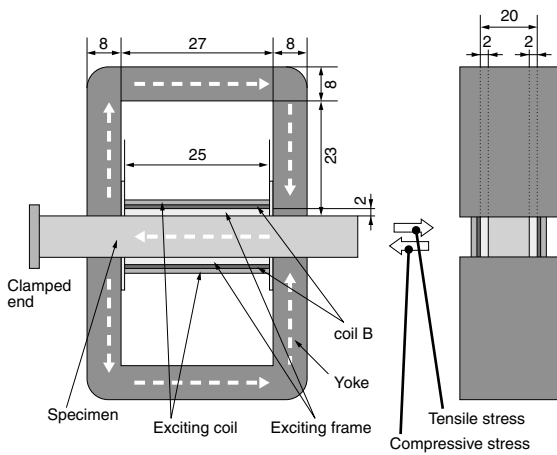

Fig. 4. Apparatus for evaluating magnetic characteristics of soft magnetic powder core under stress

The magnetic characteristics were evaluated under conditions of a sinusoidal flux. The electric current was adjusted to keep the flux sinusoidal.

Using the evaluation apparatus described above, the longitudinal flux distribution in the rectangular solid test piece was evaluated. In the test section, variations in the flux density were 1.5% at a maximum. Consequently, it could be assumed that the flux distribution was virtually uniform⁽⁵⁾.

The measured iron loss consisted of the losses in the yoke and the losses in the test piece. After measurement, the iron loss attributable to the test sample was calculated by subtracting the iron loss in the yoke from the measured sum. The obtained iron loss in the test sample was divided into the hysteresis losses and eddy current losses using the iron loss equation⁽⁶⁾ in a sinusoidal magnetic field. The major factor degrading the iron loss under an applied stress was investigated from these divided losses.

4. Experimental Results

4-1 Experimental conditions

Using the evaluation apparatus described in Section 3-3, the magnetic characteristics of the test samples were evaluated under the conditions given in **Table 2**.

In this study, the iron loss under an applied stress was compared to the iron loss observed under no-load conditions and evaluated.

Table 2. Experimental conditions

Flux Density [T]	0.5, 1.0, 1.2
Frequency [Hz]	50, 100, 400, 800, 1k
Stress [MPa]	Compressive stress 0, -25, -50, -100, -150 Tensile stress 0, 0.5, 1.0, 1.5, 2.0

4-2 Experimental results

Figure 5 shows the hysteresis loop for test sample #1 with an applied compressive stress. The magnetic permeability reduced and the coercive force increased as a result of the compressive stress, which degraded the magnetic characteristics of the soft magnetic powder core. The trends revealed were similar to those of the preceding studies involving electromagnetic steel sheets⁽¹⁾⁻⁽³⁾. **Figures 6 and 7** show the frequency and flux density dependence of the magnetic characteristics under the applied stress for sample #1. The iron loss increased with increasing frequency and flux density. Comparing the frequency characteristics of the iron loss under no-load conditions with those under a compressive stress, the higher the compressive stress, the higher the increase in the iron loss.

The results of the evaluation of iron loss for samples of different particle sizes are shown in **Fig. 8**. Individual values of iron loss under stress were normalized to the no-load values. Irrespective of the particle size of the soft magnetic powder core, the iron loss under a compressive stress increased, and by contrast, the iron loss under a tensile stress decreased. This trend is also similar to that shown for the electromagnetic

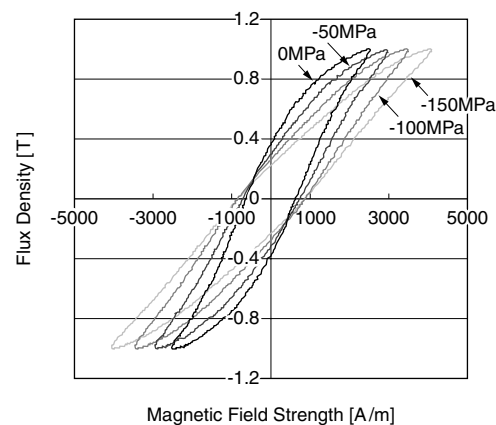

Fig. 5. Hysteresis curves with compressive stress (Sample #1)

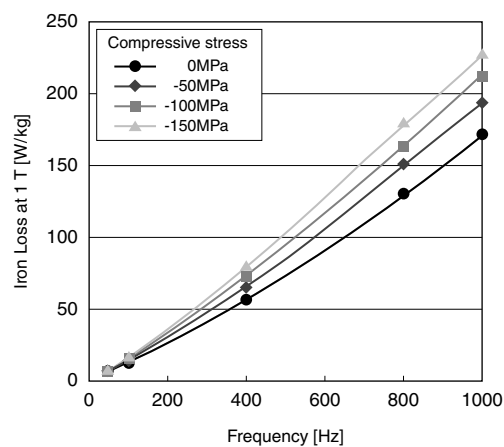

Fig. 6. Frequency dependence of iron loss at 1 T with compressive stress (Sample #1)

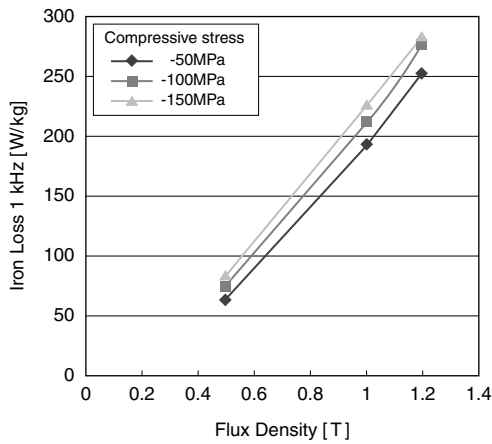

Fig. 7. Flux density dependence of iron loss at 1 kHz with compressive stress (Sample #1)

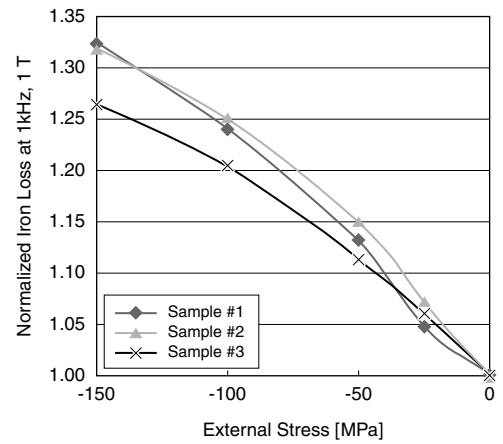

Fig. 9. External stress dependence of normalized iron loss at 1 kHz, 1 T

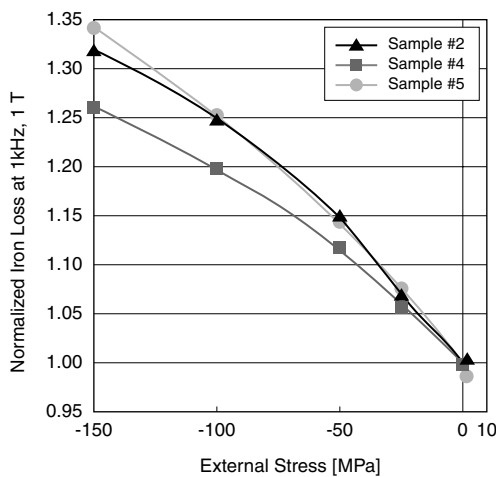

Fig. 8. External stress dependence of normalized iron loss at 1 kHz, 1 T (Negative values are compressive stresses and positive values are tensile stresses.)

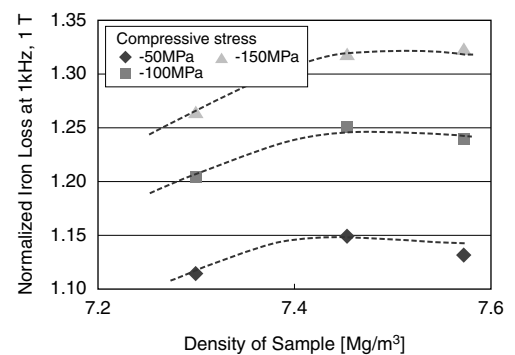

Fig. 10. Sample density dependence of normalized iron loss at 1 kHz, 1 T

steel sheets ⁽¹⁾⁻⁽³⁾. As the density of the three samples was almost equal, the increases in the iron loss in sample #4 were smaller than in the others. Sample #4 contained relatively more binder resin, which was considered to have relaxed the stress on the iron powder. The results suggest that the effect of particle size on the relationship between iron loss and applied stress is small.

The results of evaluating the iron loss for samples of different densities are shown in Fig. 9. Each value for the iron loss under the stress was normalized to the no-load value. Irrespective of the density of the samples, the iron loss under compressive stress increased. Accordingly, the relationship between the density of the samples and the increases in the iron loss is rearranged in Fig. 10. Irrespective of the amplitude of the compressive stress, the ratio of iron loss to density tended to increase in the low density range, but to be almost constant in the range where the density was 7.4 Mg/m³ and higher. It was assessed that in the low density range, there were a lot of gaps in the sample, easing the applied stress on the sample.

5. Discussion

The influence of applied stress on hysteresis losses (Wh) and eddy current losses (We) was evaluated in order to investigate the degradation in the iron loss under an applied stress.

The values of Wh and We for samples of different particle sizes are shown in Fig. 11. Irrespective of the particle size of the soft magnetic powder core, the hysteresis losses under the applied compressive stress increased, but the eddy current losses were almost constant. It was considered that the major factor in the increased iron loss was the increase in the hysteresis losses. This result was consistent with the decrease in magnetic permeability and the increase in coercive force as shown Fig. 5.

Eddy current losses are inversely proportional to the specific resistance. In order to investigate eddy current losses in detail, the relationship between the specific resistance and the applied stress was evaluated. The specific resistance was measured by the four-terminal method. The specific resistance was almost constant as shown in Fig. 12. From these results, it was conceivable that the effects of the applied compressive stress on the eddy current losses were minimal.

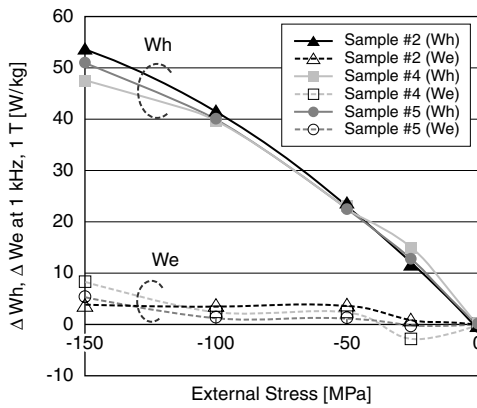

Fig. 11. External stress dependence of ΔW_h and ΔW_e at 1 kHz, 1 T

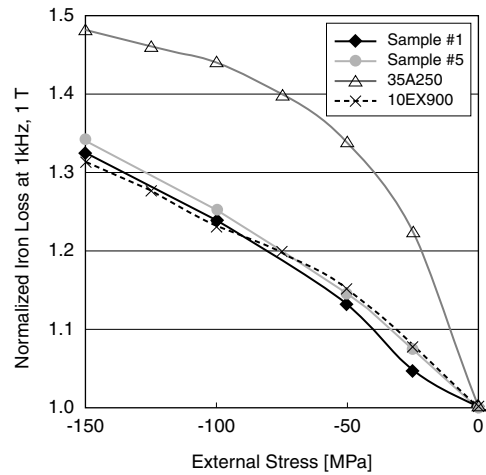

Fig. 13. Magnetic characteristics of laminated steel sheets and soft magnetic powder cores (External stress dependence of normalized iron loss at 1 kHz, 1 T)

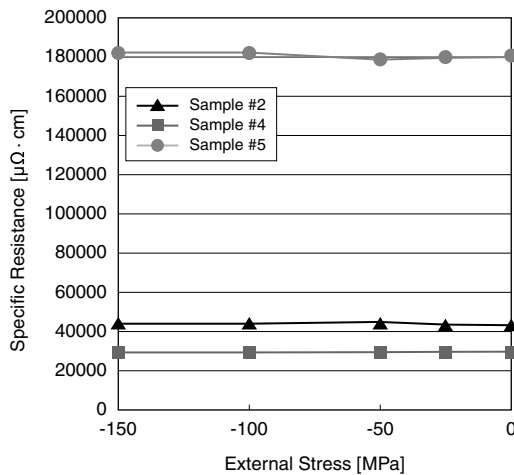

Fig. 12. External stress dependence of specific resistance

Overall, it was considered that the major factor in the degraded iron loss under an applied stress was the increase in the hysteresis losses. It was estimated that the increase in the hysteresis losses was induced by the strains generated on the samples under an applied stress.

6. Comparison of the Magnetic Characteristics of Soft Magnetic Powder Cores with those of Laminated Steel Sheets

Figure 13 shows the dependence of the external compressive stress on the normalized iron loss in soft magnetic powder cores and typical laminated steel sheets used in motors and inductors. Based on these results, the increases in the normalized iron loss in soft magnetic powder cores were smaller by approximately 20% than those in conventional laminated steel sheets used in motors (JIS 35A250). In contrast, the increases in the normalized iron loss in laminated steel sheets used in inductors were approximately the same as those in soft magnetic powder cores.

7. Conclusions

This study was carried out to evaluate the magnetic characteristics of soft magnetic powder cores under an applied stress, and the following conclusions were obtained.

① The magnetic characteristics of soft magnetic powder cores show that the magnetic permeability decreases and the coercive force and iron loss increases with an applied compressive stress, as in the case of laminated steel sheets.

② For soft magnetic powder cores, the major factor in degrading the iron loss under an applied stress was the increase in the hysteresis losses due to the applied stress.

③ Iron loss degradation in soft magnetic powder cores caused by stress was less than in conventional laminated steel sheets used in motors.

As a result, it is effective to incorporate a soft magnetic powder core in the yoke section of high-efficiency motors.

References

- (1) Yamamoto, Shimomura, Yamada, Sasaki; T.IEE Japan, Vol.117-A, No. 3, pp. 311-316 (1997)
- (2) Tani, Daikoku, Nakano, Arita, Toide, Yoshioka, Yamaguchi; The Papers of Technical Meeting on Magnetics, IEE Japan, MAG04-91, pp. 59-64 (2004)
- (3) Yamamoto, Okazaki, Fujiwara, Tani; The Papers of Technical Meeting on Magnetics, IEE Japan, MAG04-226, pp. 39-44 (2004)
- (4) Fujiwara, Nakano, Ishihara; Journal of the Magnetics Society of Japan, Vol. 28, No. 5, pp. 661-669 (2004)
- (5) Hori, Chun-Feng, Ishihara, Todaka, Yoshikawa; The Papers of Technical Meeting on Magnetics, IEE Japan, MAG06-73, pp. 43-48 (2006)
- (6) Enomoto, Kitamura, Motegi, Andoh, Ochiai, Abukawa; IEEE Trans.IA, Vol. 124, No. 6, pp. 529-535 (2004)

~~~~~

**Contributors** (The lead author is indicated by an asterisk (\*)).

**K. YOSHIKAWA \***

- Automotive Technology R&D Laboratories

**Y. YAMADA**

- Automotive Technology R&D Laboratories

**S. YAMAMOTO**

- Automotive Technology R&D Laboratories

**Y. MOCHIDA**

- Assistant Manager, Automotive Technology R&D Laboratories

**S. OHASHI**

- Assistant General Manager, Automotive Technology R&D Laboratories

**Y. FUKUNAGA**

- Assistant General Manager, Analysis Technology Research Center

**T. SAWAI**

- General Manager, Automotive Technology R&D Laboratories

**K. FUJIWARA**

- Dr. Eng., Professor, Faculty of Science and Engineering, Department of Electrical Engineering, Doshisha University

**Y. ISHIHARA**

- Dr. Eng., Director & Professor, Research Center of Applied Electromagnetic Energy, Doshisha University