

6056 Aluminum Alloy Wire for Automotive Fasteners

Isao IWAYAMA*, Tetsuya KUWABARA, Yoshihiro NAKAI, Yoshiyuki TAKAKI,
Shin-ichi KITAMURA and Hidetoshi SAITO

The need for high-strength aluminum fasteners is growing quickly with the aim of reducing the weight of automobiles. Sumitomo Electric Toyama Co., Ltd. has developed 6056 aluminum alloy wire suitable for these fasteners. Owing to its homogeneous microstructures, the wire achieved a high tensile strength of 420 MPa and yield strength of 375 MPa, as well as a maximum reduction ratio of 85% without surface cracks in a compressive test at room temperature. These features will enable fastener manufacturers to improve their productivity.

Keywords: aluminum, aluminum alloy, fastener, 6056, forging

1. Introduction

Aluminum is a light weight, strong, highly electrically conductive, and corrosion-resistant metal. Owing to these characteristics, aluminum is used extensively in basic facilities, such as power transmission lines, in automotive and in home appliance applications. It is an essential metal to the infrastructure of our industrial society.

Sumitomo Electric Toyama Co., Ltd., a member of the Sumitomo Electric Group, manufactures and sells a variety of high-quality aluminum wire products including large-scale transmission lines, aluminum alloy wires for automotive parts, and aluminum wires for electronic equipment.

To meet the needs of weight reduction in the automotive industry, Sumitomo Electric Toyama has recently developed a 6056*¹ aluminum alloy wire, which has a high mechanical strength and workability; suitable for aluminum fastener applications. In this review, we would like to explain its excellent properties and microstructure.

2. Aluminum Wire Manufactured by Sumitomo Electric Toyama

Table 1 lists the aluminum wire products of Sumitomo Electric Toyama. The company manufactures aluminum alloy wires using the method based on the Properzi continuous casting⁽¹⁾ (**Fig. 1**).

This method enables fast solidification in the aluminum casting process and eliminates the need of reheating in the rolling process, thus improving productivity. This method also accelerates the dissolution of solute elements and the dispersion of fine precipitates, making the resulting alloy wire strong and workable.

The features of the Properzi method are typically utilized in the automotive aluminum wiring harnesses^{(2)*2} that the Sumitomo Electric Group has commercialized ahead of its competitors in the world.

Alloys used in aluminum wiring harnesses need to have high electrical conductivity*³ and strength, as well as sufficient drawability for the production of small-diameter wires. The alloy used in Sumitomo Electric's aluminum

Table 1. Aluminum wire manufactured by Sumitomo Electric Toyama

Alloy series	No	Features
Pure aluminum	1050 1070 1080 1100 1200	Pure aluminum wires with impurity levels of less than 1%. Their features include high electrical conductivity, workability, corrosion resistance, and weldability.
Al-Cu	2011 2014 2017	Alloys of aluminum known as "duralumin" that contain copper and are exceptionally strong and hard. They are also known as free-cutting alloys due to their ease of cutting.
Al-Mn	3003	An alloy made by mixing pure aluminum with 1.5% manganese, approximately 20% stronger than pure aluminum. The Al-Mn series features high corrosion resistance and workability.
Al-Si	4043	An alloy made by mixing pure aluminum with 4%-12% silicon. This alloy has excellent fluidity due to its low melting point. Its applications include welding rods and brazing filler metals. It forms a natural dark gray anodic coating and has a low thermal expansion coefficient.
Al-Mg	5052 5056 5356 5183 5154	Alloys made by mixing pure aluminum with 0.3%-5% magnesium. These alloys offer high strength and resistance to seawater. Among other aluminum alloys, this series is used for the widest applications including welded structures. These alloys are easily anodized and colored.
Al-Mg-Si	6061 6063 6151	Heat-treatable alloys that feature high strength, workability, and corrosion resistance. This alloy series is also easily anodized and colored.
Al-Zn	7072	An aluminum alloy that features relatively high weldability and corrosion resistance. It is a high-strength, aging alloy.

wiring harnesses is an epoch-making alloy because it has both a tensile strength of 120 MPa and an electrical conductivity of 60% IACS. These characteristic features were achieved by adding a high proportion (1.05 wt%) of iron, which has a very low solid solubility, with the aim of increasing the strength of the alloy with dispersed Al-Fe compounds while maintaining its electrical conductivity.

If billet casting and extrusion, which are common

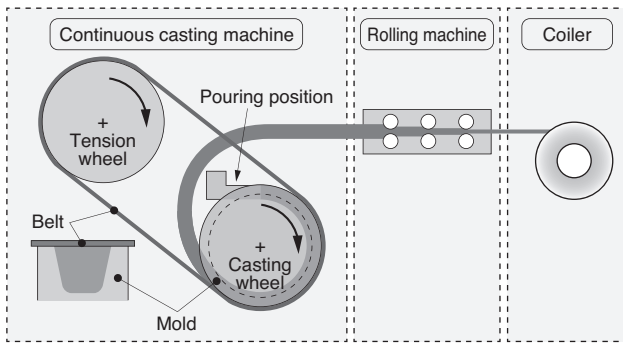

Fig. 1. Diagrammatic drawing of continuous casting and rolling processes

processes for the fabrication of wires, are carried out, Al-Fe compounds will crystallize coarsely and reduce the alloy's drawability, thus making the alloy unsuitable for cable harness applications. By contrast, as Sumitomo Electric Toyama introduces continuous casting and rolling process for manufacturing wires, alloy is solidified quickly and Al-Fe compounds are dispersed finely. Consequently, the alloy can maintain its drawability to be used for cable harnesses.

3. Automotive Fasteners

3-1 Growing demand for aluminum fasteners

To prevent global warming, carbon dioxide emissions control is being imposed on automobile manufacturers on a global scale. The regulations on emissions control are to be tightened gradually in the future. For this reason, automobile manufacturers are actively working to improve fuel efficiency by raising the efficiency of internal combustion engines and reducing vehicle weight through the use of aluminum and magnesium parts. Automotive aluminum parts are diverse, including those for the aforementioned wiring harnesses, body panels, oil pans, engine mounts, and hydraulic control valves in automatic transmission cars.

To fasten aluminum and magnesium parts, steel fasteners are mainly used. However, steel fasteners are easily loosened due to the difference of the thermal expansion coefficient between the steel fastener and aluminum or magnesium parts and corrode by galvanic reaction. For sufficient reliability, the fastened parts need to have deep threaded holes, implying an increase in thickness, as shown in Fig. 2.

In contrast, aluminum fasteners can reduce vehicle weight since the fasteners weigh less and require thinner parts thickness.

For aluminum and magnesium parts, aluminum fasteners are beneficial and widely used particularly in Europe as they can reduce more weight than steel fasteners.

3-2 Property and material requirements for aluminum alloy wires for fasteners

For fastener applications, aluminum alloy wire needs to meet strength requirements and exhibit heat resistance to maintain its strength at a high temperature of 150°C. It

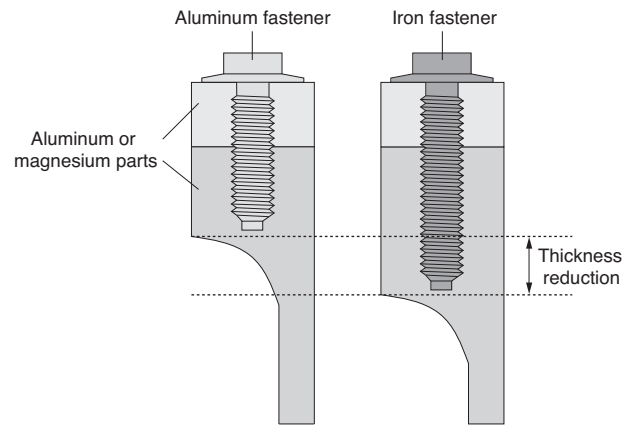

Fig. 2. Relationship between fastener materials and thickness requirement
Left: aluminum fastener
Right: steel fastener

also needs to be corrosion resistant to avoid stress corrosion cracking^{*4}. Moreover, the wire should possess good workability to be shaped into fasteners.

Figure 3 shows a general aluminum fastener manufacturing process. The material is an aluminum alloy wire, which is manufactured by wire manufacturers such as Sumitomo Electric Toyama, and shipped as a work-hardened or annealed material. Fastener manufacturers cut alloy wire into the desired length and form fastener heads through multiple cold forging steps. After being processed into the T6 material^{*5} through solution heat treatment and aging, the material undergoes form rolling^{*6} to be drawn into aluminum fasteners.

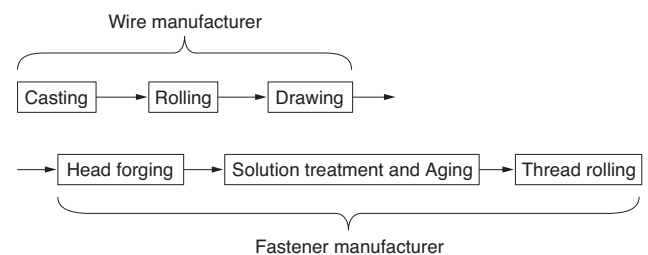

Fig. 3. General manufacturing method for aluminum fasteners

The most demanding working step in the fastener manufacturing process is forging the fastener heads. The deformation ratio in this forging step is approximately 70%, although it depends on the head geometry. Alloy wire for aluminum fasteners is required to keep sufficient forgeability to undergo deformation without making cracks or creases in surface layer.

Table 2 shows the general properties of structural aluminum alloys. Alloys of the 6000 (Al-Mg-Si) series are suitable for automotive fasteners since they meet the four automotive fastener requirements of strength, heat resist-

Table 2. General properties of aluminum alloys

Class		Strength	Workability	Heat resistance	Corrosion resistance
2000 (Al-Cu) series		○	△	△	×
5000 (Al-Mg) series		△	△	△	△
6000 (Al-Mg-Si) series	General-purpose	△	○	○	○
	High-strength	○	△	○	○
7000 (Al-Zn) series		◎	△	×	×

◎ very good, ○ good, △ not very good, × not good

ance, corrosion resistance and workability at relatively high levels.

In Europe in recent years, a high-strength aluminum alloy of the 6000 series (6056 aluminum alloy) has been used in automotive fastener applications. **Table 3** shows the chemical compositions of a 6056 aluminum alloy. **Table 4** shows the typical mechanical properties of automotive fasteners made of the 6056 aluminum alloy.

Table 3. Chemical Compositions of 6056 aluminum alloy (wt%)

Si	Mg	Fe	Cu	Mn	Cr	Zn	Ti+Zr
0.7 ~1.3	0.6 ~1.2	≤0.5	0.5 ~1.1	0.4 ~1.0	≤0.25	0.1 ~0.7	≤0.2

Table 4. Mechanical properties of automotive fasteners made of 6056 aluminum alloy

Tensile strength	400MPa
0.2% yield strength	360MPa
Elongation	8%

4. Development of 6056 Aluminum Alloy Wire for Automotive Fasteners

4-1 Development policy

Aluminum alloy wire for fastener applications is required to possess forgeability suitable for being cold-forged into fastener heads from the state of a work-hardened or softened material. However, 6056 aluminum alloy is relatively difficult to forge for reasons stated later, although it has excellent mechanical strength, heat resistance and corrosion resistance. The existing 6056 aluminum alloy can certainly be forged into fastener heads. Nonetheless, we started studying how to make improvements to the forgeability of 6056 aluminum alloy to help increase yields at fastener manufacturers.

4-2 Mechanisms of decreasing forgeability and countermeasures

When performing forging or other plastic deformation, heterogeneous materials deform first in relatively vulnerable sections. This may result in defects such as creases

in surfaces and cracks caused by local stress concentration.

Heterogeneity arises from (1) coarse precipitates and (2) non-uniform grain size. Both of these must be reduced for improved forgeability. Meanwhile, (1) coarse precipitates develop primarily in the casting process and (2) non-uniform grain size mainly occurs during the hot rolling and drawing processes.

Among the 6000 series alloys, 6056 aluminum alloy used to manufacture aluminum alloy wire for fasteners principally in Europe is alloyed with particularly high proportions of mixed elements. Alloys containing high proportions of alloy elements tend to cause segregation and form coarse precipitates during casting. This is the main cause of the decrease in forgeability.

We presumed that, it would be possible to improve the forgeability of even those alloys containing high proportions of alloy elements such as 6056 aluminum alloy by optimizing the casting process so as to avoid the coarse precipitates and by optimizing the hot rolling and drawing processes in order to uniformize the grain size.

4-3 Casting process improvements

In general, the faster the cooling rate in the casting process is, the smaller precipitates sizes are. We therefore aimed to reduce coarse precipitates by improving the casting mold cooling efficiency to increase the cooling rate. We then optimized the mold geometry and casting conditions by using simulations and also applied accurate control of cooling directions to avoid hot spots. As the result, we succeeded in casting 6056 aluminum alloy containing high proportions of alloy elements with almost no coarse precipitates.

4-4 Improvements of rolling and drawing processes

Next, we optimized the rolling and drawing conditions, with the best use of microstructure control technology, and successfully achieved uniform-sized grains.

Through these improvements, we succeeded in making a 6056 aluminum alloy wire that has only a few level of coarse precipitates and a relatively uniform grain size.

4-5 Microstructure of newly developed material

Figure 4 shows EBSD^{*7} images of a work-hardened 6056 aluminum alloy wire prepared by the original process (heterogeneous material) and a work-hardened 6056 alu-

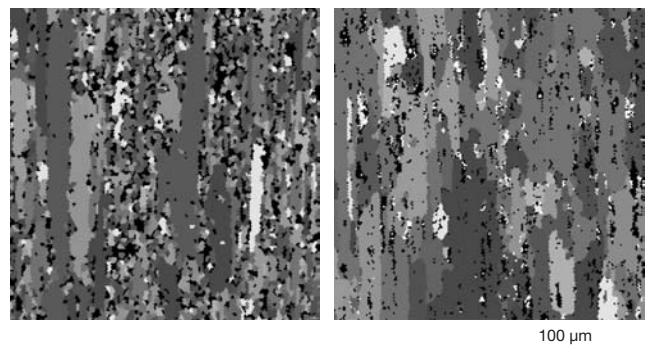

Fig. 4. EBSD image of newly developed material
Left: heterogeneous material (before improvement)
Right: newly developed material

minum alloy wire made through an improved process (newly developed material). Areas filled in with a single color represent one crystal grain. Compared with the heterogeneous material, the newly developed material is highly uniform in grain size.

4-6 Forgeability of newly developed material

Test specimens that had a diameter to height ratio of 1:2 were cut from the newly developed material and the heterogeneous material to simulate fastener head forging. They were compressed and deformed in stages to a deformation ratio of 85%. **Table 5** shows the deformed test specimens.

The appearances of test specimens deformed to a deformation ratio of 85% were compared with each other. Cracks developed in the heterogeneous material, while no cracks developed in the newly developed material, proving that the deformation limit of the newly developed material is very high at 85% or more. Moreover, a comparison of test specimens worked on to a deformation ratio of 75% without the development of cracks showed that the heterogeneous material had deep creases on the surface, while the newly developed material was exceptionally smooth.

Table 5. Deformation test results for newly developed material

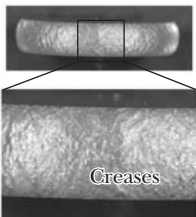
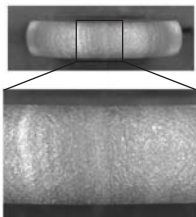
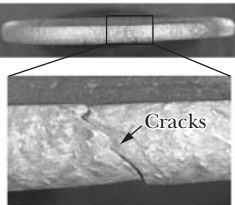
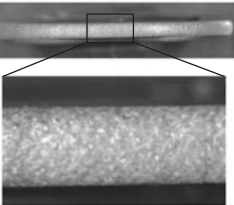
	Heterogeneous material (before improvement)	Newly developed material
Deformation ratio 75%		
Deformation ratio 85%		

Consequently, the newly developed material was found to possess excellent forgeability. This material has a high deformation limit of over 85%, providing a sufficient margin to the deformation ratio in faster head forging of 70%.

4-7 Mechanical properties of newly developed material

Table 6 shows the mechanical properties of the T6 material, which has similar properties to shaped aluminum fasteners. The newly developed material is comparable to the commercially available 6056 material in terms of tensile strength, yield strength, and elongation, proving that it has the high mechanical strength typically seen with 6056 material. Consequently, fasteners fabricated from the newly developed material are believed to adequately meet the property requirements for automotive applications.

Table 7 shows the mechanical properties of T6 mate-

Table 6. Mechanical properties of newly developed material (T6)

	Newly developed material (Typ.)	Commercially available 6056	
		(Typ.)	(Min.)
Tensile strength [MPa]	420	420	380
0.2% yield strength [MPa]	375	375	350
Elongation [%]	12	12	6

Table 7. Heat resistance of newly developed material (T6)

	Before heat treatment	After heat treatment at 150°C
Tensile strength [MPa]	420	385
0.2% yield strength [MPa]	375	355

rial after heat load test of keeping at 150°C for a long time. After the heat test, the newly developed material showed more than 90% of the mechanical strength of the pre-heat treatment material, proving that the newly developed material has a high heat resistance.

5. Conclusion

Sumitomo Electric Toyama has developed a 6056 aluminum alloy wire that has been in growing demand as the key material for automotive fasteners.

Owing to its fine precipitates and uniformly-sized grains, this alloy wire has a high mechanical strength, i.e. a tensile strength of 420 MPa and a yield strength of 375 MPa, as well as a high deformation limit of 85%. Its high forgeability is expected to help fastener manufacturers improve their yields.

We will continue to work on the optimization of alloy composition to develop the Sumitomo Electric Group's original alloys that have marvelous strength beyond the 6056 specifications.

Technical Terms

- *1 6056: A designation of an aluminum alloy. The Aluminum Association-specified alloy number 6056 refers to alloys containing Al, Mg and Si as the principal constituents.
- *2 Aluminum wiring harness: An assembly for in-vehicle applications, in which multiple electrical wires made of an aluminum alloy are bundled together for power supply and signal transmission purposes.
- *3 Electrical conductivity: An index that measures the ability of a material to conduct an electrical current. It is expressed as a proportion of the electrical conductivity

of soft copper taken as 100 (soft copper's electrical resistivity: $1.7241 \times 10^{-2} \mu\Omega\text{m}$). The unit of electrical conductivity is %IACS.

- *4 Stress corrosion cracking: Cracks resulting from the application of tensile stress to a metallic material placed in a corrosive environment. Stress corrosion cracking develops in the presence of three factors: material, stress, and environment.
- *5 T6 material: A material artificially age-hardened without undergoing active cold working after solution heat treatment.
- *6 Form rolling: A type of plastic forming process for threads, in which a revolving rod material is squeezed through a tool known as a rolling die.
- *7 Electron backscatter diffraction (EBSD): An analysis method making use of electron backscatter diffraction to determine the crystal grain orientation in a sample.

References

- (1) Y. Hanaki et al., "Development of Hard Alloyed Aluminum Rod on the Continuous Casting and Rolling Process," Sumitomo-Denki 139, 1991, 83-87p
- (2) Y. Murakami (Ed.), Aruminiumu Zaiyou no Kiso to Kougyougijutsu (The Bases and Industrial Technology of Aluminum), Japan Light Metals Assoc., 1985, 441p.
- (3) Y. Yamano et al., "Development of Aluminum Wiring Harness." SEI TECHNICAL REVIEW 73(2011), 73-80.
- (4) Y. Baba (Ed.), Aruminiumu Gijutsu Binran / Shin-ban (The handbook of Advanced Aluminum Technology / New Edition), Kallos Publishing Co., Ltd., 1996, 1322p.
- (5) S. Ouya (Ed.), Aruminiumu Chu-Tanzo Gijutsu Binran (The Handbook of Technology for Casting and Forging Aluminum). Kallos Publishing Co., Ltd., 1991, 1410p.
- (6) H. Hayashi (Ed.), Aluminum Handbook / Seventh Edition. Japan Aluminum Association, 2007, 324p.

Contributors (The lead author is indicated by an asterisk (*).)

I. IWAYAMA*

- Electronics & Materials R&D Laboratories



T. KUWABARA

- Doctor of engineering
Manager, Electronics & Materials R&D Laboratories



Y. NAKAI

- General Manager, Electronics & Materials R&D Laboratories



Y. TAKAKI

- Engineering Department, Sumitomo Electric Toyama Co., Ltd.

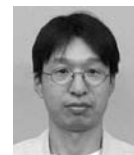

S. KITAMURA

- Manager, Engineering Department, Sumitomo Electric Toyama Co., Ltd.

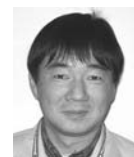

H. SAITO

- General Manager, Engineering Department, Sumitomo Electric Toyama Co., Ltd.

