

# Waterproof Optical Connector with Multiple Interfaces

Yuji SUZUKI\*, Masashi OKA, Junji FUKUI, Motoyoshi KIMURA and Kenichiro OHTSUKA

With the development of mobile networking along with the spread of machine-to-machine communication and the internet of things concept, optical communication devices have been used in various environments including outdoors. This has created the need for optical connectors that can withstand harsh environments while supporting multiple interfaces. To meet this demand, we have developed a waterproof optical connector that is compatible with multiple interfaces. Coming with the IP68 rating, the connector is highly resistant to dust and water, and thus suitable for outdoor use. The product can also be connected easily to SC, LC, and MPO (multi-fiber push on) connectors, as well as to SFP (small form-factor pluggable) transceivers.

Keywords: mobile networking, waterproof optical connector, SC connector, LC connector, MPO connector

## 1. Introduction

With the spread of the Internet in various ways, such as fiber to the home (FTTH) and mobile devices, transmission capacity is increasing and outdoor communication equipment is increasingly being introduced.

When building conventional outdoor equipment, optical cable was fed into the case and then fusion-bonded to the fiber equipped with an optical connector. Subsequently, the cable was connected to the device in the equipment using a cord equipped with an optical connector. Recently, however, the cable equipped with an optical connector is required to be connected directly to the equipment for the downsizing of the equipment.

To meet such a need, (1) since connectors such as single-mode fiber coupling (SC), a little connector (LC), and multi-fiber push-on (MPO) connectors are used, the optical cable must be compatible with their connection interfaces, and (2) it must be waterproof. Consequently, we have developed a waterproof optical connector compatible with such optical connection interfaces on which we report in this paper.

## 2. Problems with Conventional Waterproof Optical Connectors

The following demands and problems have been identified for conventional waterproof optical connectors:

- (1) To be compatible for outdoor use, all components besides the ferrule are dedicated metallic components that contribute to robustness but cause poor usability due to the heavy weight.
- (2) Multiple operational steps must be taken to securely fit the waterproof optical connector that is directly connected to the optical device, a small form factor pluggable (SFP) transceiver, which has been increasingly used in recent years due to variability in the mounting position of the waterproof optical connector inside the transceiver equipment.

- (3) Since dedicated components are used, the connector is not compatible with multiple optical connection interfaces, eventually limiting the variety of items that can be used.

## 3. Structure and Functions of the Developed Waterproof Optical Connector

Figure 1 shows the external appearance of the waterproof optical connector developed to solve the problems of conventional waterproof optical connectors.

The connector and the optical connection part of the receptacle utilize a standard optical connector and adapter (“A” in Fig. 1). They are structurally covered using a waterproof shell (“B” in Fig. 1). A resin excellent in weather resistance, similar to the resin used for such components as enclosures, is adopted for the waterproof shell, thus reducing the weight by 51% from the equivalently sized conventional connector.

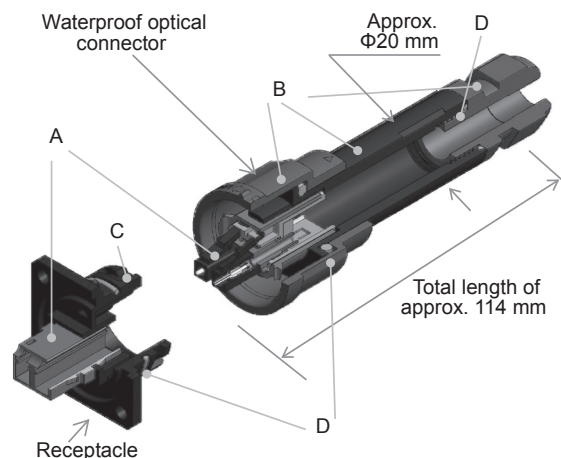

Fig. 1. External appearance of the waterproof optical connector

With a focus on outdoor usability, the dimensions of the connector are not reduced, with a total length and external diameter of about 114 mm and 20 mm, respectively. The size of the usable optical cable ranges widely from 5 to 10 mm in diameter.

As the fitting method, a bayonet-lock\*1 structure (“C” in Fig. 1) is used to allow easy single-handed connection.

The waterproof structure employs the O-ring method (“D” in Fig. 1), which has a proven record of success in sealing performance. By fitting the O-ring to the component connection area, the connector clears the test for waterproof performance equivalent to IP68 (5 m underwater for 3 hours).

### 3-1 Easy fitting into the SFP transceiver

As shown in Fig. 2, the mounting position of the SFP transceiver built into the communication equipment is determined by the positions of the equipment case (bezel), the base plate, and the case accommodating the SFP transceiver (cage) to be mounted to the base plate.

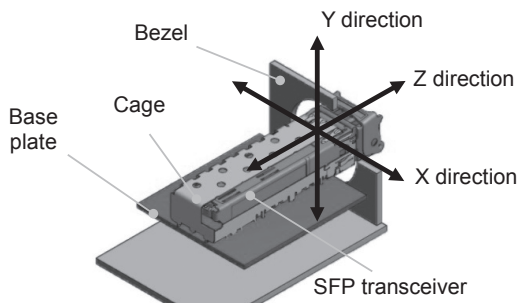

Fig. 2. SFP transceiver mounting position

Consequently, there is variability in the position due to the accumulation of the tolerances associated with individual components in the X, Y, and Z directions, and the receptacle and waterproof optical connector used for fitting must absorb this variability in position. Figure 3 shows a general fitting operation into the SFP transceiver that requires about five steps for the fitting operation.

This is mainly attributable to the variability in the position in the Z direction, and these steps are taken for a secure fitting as well as for avoidance of pressing force after fitting.

Consequently, we conducted a study on the connector structure that absorbs the variability in the position in the Z direction. The mechanism that allowed the connector interface itself to move in the Z direction was incorporated into the connector. Figure 4 shows the structure of our waterproof optical connector and Fig. 5 illustrates the fitting structure.

The structure with a spring built into the receptacle achieved the mechanism to push down the main body of the waterproof optical connector after the SFP transceiver and the connector were fitted together, thus avoiding the pushing force on the SFP transceiver.

This allowed a three-step operation for fitting into the SFP transceiver (Fig. 6).

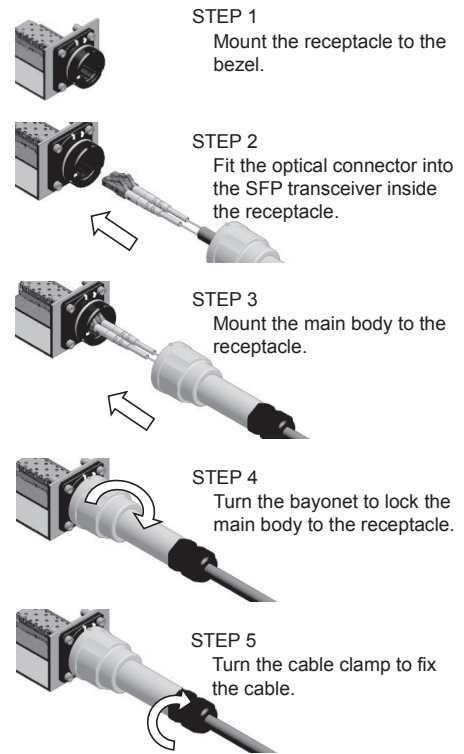

Fig. 3. General fitting operation into the SFP transceiver

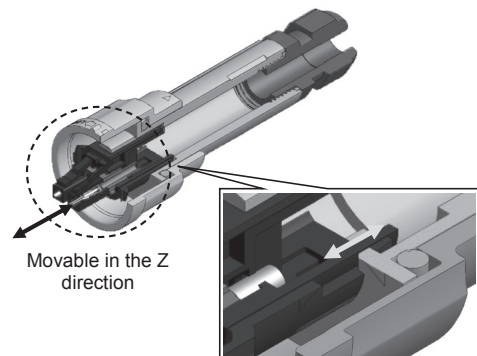

Fig. 4. Structure of the waterproof optical connector for the SFP Transceiver

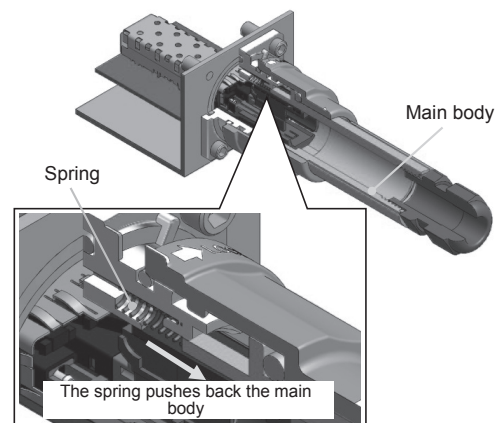

Fig. 5. Fitting structure of the SFP transceiver and the waterproof optical connector

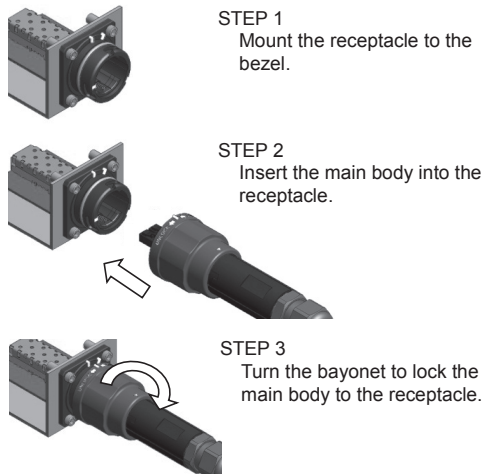

Fig. 6. Fitting operation for the SFP transceiver and our waterproof connector

### 3-2 Compatibility with interfaces

Using the waterproof shell commonly used for general optical connectors, our waterproof connector achieves compatibility with various types of optical connection interfaces only by replacing the standard optical connector and adapter (Fig. 7).



Fig. 7. Interfaces for the waterproof optical connector

## 4. Prototype Evaluation Results

The initial optical characteristics (insertion loss and return loss <UPC\*2>) when the waterproof optical connector with an LC connector type was connected to a two-core cable (SMF: ITU-T G.657.A1) are shown in Fig. 8, and the heat cycle test results are shown in Fig. 9. The results of the test conducted according to Telcordia GR-326-CORE issue 3 are summarized in Table 1. In all cases, results adequately satisfied the standards in terms of connector performance.

## 5. Conclusion

We have developed and commercialized an outdoor-use waterproof optical connector compatible with multiple optical connection interfaces. Going forward, we will begin the development of a waterproof optical connector that can be assembled on site by applying the essence of this design

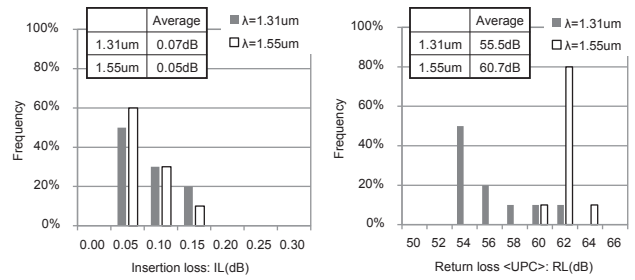

Fig. 8. Initial optical characteristics of the waterproof optical connector (LC-type)

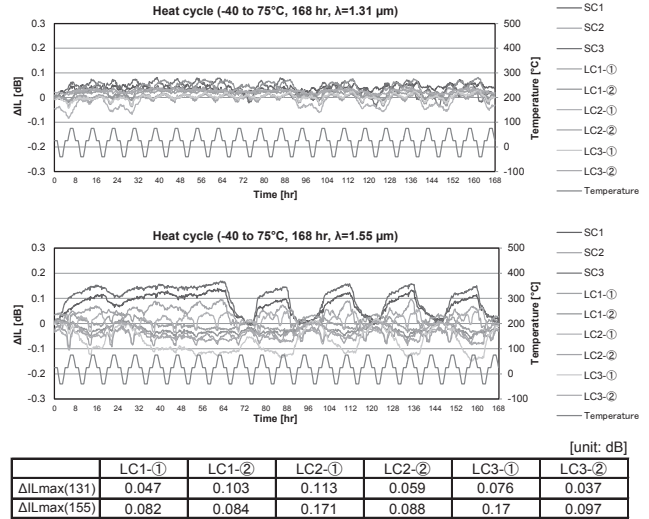

Fig. 9. Heat cycle test results of the waterproof optical connector (LC-type)

Table 1. Reliability test results of the waterproof optical connector (LC-type)

	Item	Condition	Criteria (Requirements)	Result
Temperature and Humidity Tests	Thermal Aging (7 days)	85 deg C	Loss Increase: 0.30 dB	0.16 dB
	Thermal Cycling (7 days)	-40 to 75 deg C 8hrs/cyc	Loss Increase: 0.30 dB	0.17 dB
	Humidity Aging (7 days)	75 deg C, 95%	Loss Increase: 0.30 dB	0.22 dB
	Humidity - Condensation Cycling (7 days)	-10 to 65 deg C 12hrs/cyc	Loss Increase: 0.30 dB	0.18 dB
	Dry-out Step (1 day)	75 deg C	n/a	-
Mechanical Tests	Vibration	10-55 Hz, 1.5 mm (p-p) 3 axes, 2 hrs/axis	Loss Increase: 0.30 dB RL: 40 dB (UPC)	$\Delta$ IL 0.02 dB min RL 52.5 dB
	Flex	0.9 kgf, +/-90 deg, 100 cycles	Loss Increase: 0.30 dB RL: 40 dB (UPC)	$\Delta$ IL 0.04 dB min RL 52.0 dB
	Twist	Media Type I: 1.35 kgf, +/-2.5 turns, 10 cycles Media Type II: 0.75 kgf, +/-1.5turns, 10cycles	Loss Increase: 0.30 dB RL: 40 dB (UPC)	$\Delta$ IL 0.08 dB min RL 51.1 dB
	Proof (Media Type I only)	<u>Straight Pull:</u> 4.5 kgf (R) 6.8 kgf (O) <u>Side Pull:</u> 2.3 kgf (R) 3.4 kgf (O)	Loss Increase: 0.30 dB RL: 40 dB (UPC)	Straight Pull $\Delta$ IL 0.08 dB min RL 55.0 dB Side Pull $\Delta$ IL 0.09 dB min RL 53.7 dB
	Impact	1.5 m height, 8 times	Loss Increase: 0.30 dB RL: 40 dB (UPC)	$\Delta$ IL 0.05 dB min RL 53.1 dB
	Durability	200 insertions	Loss Increase: 0.30 dB RL: 40 dB (UPC)	$\Delta$ IL 0.17 dB min RL 53.7 dB
	Waterproofing	IP68 (The depth of the water 5 m × 3 hr)	no leak of water	no leak of water

in order to broaden our product lineup and meet market needs.

#### Technical Terms

- \*1 Bayonet Lock: A structure comprising a component having a convex part and another component having a concave part along the said convex part, which enables easy attachment and removal by rotating either of the components. This structure is frequently used to mount a camera lens.
- \*2 UPC (Ultra Polished Physical Contact): A kind of optical connector spherical polishing method. This method generally corresponds to a return loss of 50 dB or more.

~~~~~  
**Contributors** The lead author is indicated by an asterisk (\*).

#### Y. SUZUKI\*

• Manager, SEI Optifrontier Co., Ltd.



#### M. OKA

• SEI Optifrontier Co., Ltd.



#### J. FUKUI

• Assistant Manager, SEI Optifrontier Co., Ltd.



#### M. KIMURA

• Assistant Manager, NIHON TSUSIN DENZAI, Ltd.



#### K. OHTSUKA

• Manager, SEI Optifrontier Co., Ltd.

