

SOA Module for 100GBASE-ER4

Ryota TERANISHI*, Yasuyuki YAMAUCHI, Yasushi FUJIHARA, Satoru KANEMARU, Tsutomu ABE and Keiji SATOH

The authors have developed a semiconductor optical amplifier (SOA) for a 100 GE CFP transceiver module. The design and packaging of the optical coupling system have been optimized for downsizing, and an optical fiber with a small bend radius was adopted for flexible layout. The amplifier meets the IEEE 802.3ba 100GBASE-ER4 standard, and features a gain bandwidth covering the LAN-WDM bandwidth and low polarization dependence of the gain.

Keywords: semiconductor optical amplifier (SOA), 100GBASE-ER4, CFP transceiver, IEEE802.3ba

1. Introduction

Due to the increase of data traffic on optical fiber in recent years, demands for faster data transmission such as 40 Gbit/s and 100 Gbit/s (25x4 Gbit/s) have increased.

The Centum gigabit Form Factor Pluggable (CFP) optical transceiver is standardized for 100G Ethernet. Optical amplifiers, which are not needed for 10 km transmission (LR4) modules, are built into 40 km transceivers (ER4) to compensate for transmission loss generated due to the long fiber distance. For its small size and amplification wavelength band, the semiconductor optical amplifier (SOA) is selected instead of the fiber amplifier.

We have developed a small SOA module for the CFP optical transceiver. The SOA module was miniaturized by optimizing the internal components. Also, we have achieved SOA amplification characteristics required for the long-distance transmission of 100GBASE. In this paper, we report on the design and characteristics of the SOA module.

Four-channel optical signals transmitted 40 km are simultaneously amplified by the SOA module, and put into the receiving elements through the Optical Demux.

Table1 shows the specifications of the SOA module. SOA modules are required to amplify the input signals to the power level of short-range transmission (LR4: 10 km) from the lower optical power level after the long-distance transmission (ER4: 40 km).

According to the IEEE802.3ba 100GBASE standard, the difference between the minimum receiver sensitivity level of OMA = -8.6 dBm for LR4 and that of OMA = -21.4 dBm for ER4 is the minimum required gain. With a 1 dB margin for the degradation, the target SOA gain was set to be 14 dB.

In order to place the SOA module in a CFP optical transceiver of 145.0 mm x 82.0 mm x 13.6 mm, significant downsizing is required from the existing SOA module. The target module size was the total length of less than 45 mm, width of less than 12 mm, and height of less than 6.5 mm.

2. Development / Specification

An SOA module is used as a pre-amplifier for loss compensation. The function of the SOA in a CFP optical transceiver is shown in **Fig. 1**. The SOA module is installed in front of the receiver of the CFP optical transceiver.

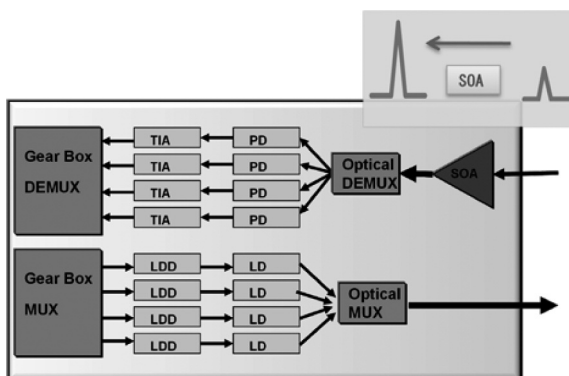

Fig. 1. SOA design in CFP optical transceiver

Table1. Target specifications of SOA module

Operation Case Temperature	-5 ~ +75 deg. C
Mechanical Dimension	Total length 40.1 mm, Overall width 10.6 mm, Overall height 5.8 mm. *Not include optical fiber / optical connector / terminal lead.
Optical Interface	Pigtail fiber both side Optical connector (LC connector /without connector)
Electrical Interface	8-PIN lead terminal
Amplified Signal Wavelength Range	1294 ~ 1315 nm
Operating Current	250 mA Max.
Gain	+14-+22 dB
Polarization Dependent Gain	2.5 dB
Saturation Output Power	+7.0 dBm
Dissipation Power	MAX. 2.5 W

3. Structure of SOA Module

The newly developed SOA module and existing SOA module (butterfly type) are shown in Fig. 2. The cross-section of an SOA module is shown in Fig. 3.

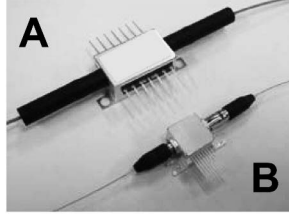

(A: Butterfly model B: New module)

Fig. 2. Size comparison with butterfly model

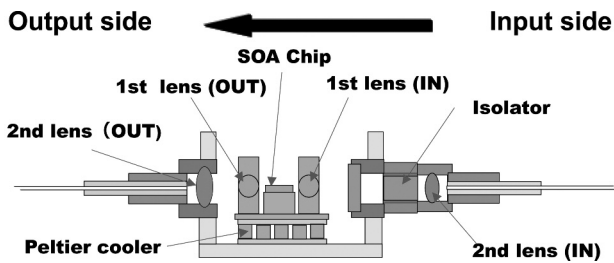

Fig. 3. Module design

In order to reduce the module size, the designs of the Peltier cooler and the second optical lens holder have been optimized. The new SOA module is designed to have a flange on one side for fixing the package and electrical leads. The occupied volume of the new SOA module was only 30% of that of the existing SOA module (butterfly type).

To minimize the optical coupling loss, the optical path of the new SOA module is laid out to be straight from the input to the output. Input light is collimated by the second lens (IN) at the fiber end of the SOA module and passes through the polarization-independent isolator. The input light is then enters the active layer of the SOA chip by the first lens (IN) within the package. The input light is amplified in the active layer and the output light is emitted from the opposite side of the SOA Chip. Amplified light is collimated by the first lens (OUT) and the amplified light focused by the second lens (OUT) enters the fiber on the output side. The optical fiber with a minimum bending radius of 7.5 mm is adopted. The minimum bending radius fiber of the conventional SOA module is 20.0 mm. The selected optical fiber is Sumitomo Electric Industries, Ltd.'s tight bend fiber, PureAccess-A2. It provides flexibility for fiber layout in a transceiver. The block diagram and pin function of the SOA module is shown in Fig. 4.

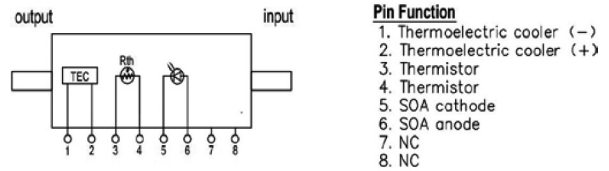

Fig. 4. Block Diagram / Pin Function

The SOA chip is located on a Peltier cooler to keep the operation temperature constant depending on the feedback from the thermistor. The SOA module is assembled with the first lens (IN and OUT) and the SOA chip carrier mounted on the Peltier cooler.

4. Characteristics-1 (gain)

The basic characteristics such as gain, polarization dependent gain (PDG) and saturation power (PS) of the SOA were evaluated. The SOA current dependent gain is shown in Fig. 5 and the characteristics of the saturation gain is shown in Fig. 6.

Input signal wavelengths are the shortest-wavelength (L0: 1294.60 nm) and the longest-wavelength (L3: 1310.10

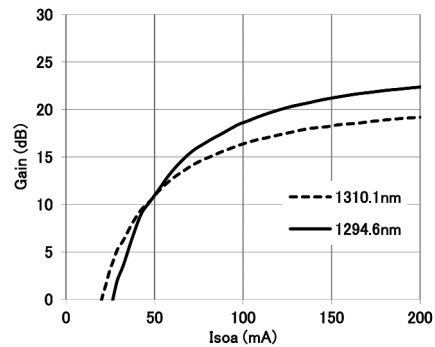

Fig. 5. Current dependence of gain

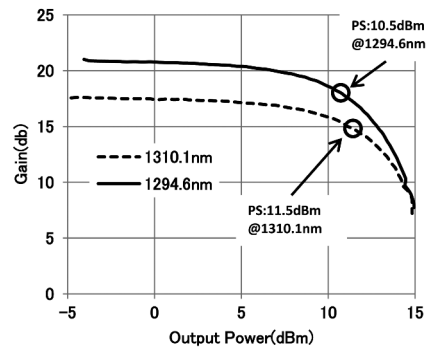

Fig. 6. saturation characteristic

nm) of those specified for LAN-WDM.

A gain of 14 dB (target specification) or more was confirmed at an SOA current of 80 mA. Additionally, saturation optical power levels at L0 and L3 were 11.5 dBm and 10.5 dBm, respectively, achieving the target (7 dBm or more).

The signal wavelength dependence of the gain and PDG are shown in Fig. 7. The evaluation conditions are as follows. The SOA current is 130 mA, the operating temperature is 25 deg. C, and the input signal power is -20.9 dBm.

Generally the SOA gain is highly dependent on the polarization state of the input light. High polarization dependency causes the variation of input power to be transmitted to the receiver. Therefore the polarization dependence needs to be small.

The SOA chip has been designed to reduce the PDG by optimizing the structure. The PDG was 0.5 dB or less at L0/L3 signal wavelength, which confirmed the good polarization characteristics of the SOA module.

Additionally, the gain with the simultaneous input of four signals (LAN-WDM) was evaluated. The SOA module needs to amplify four wavelength signals simultaneously. Considering the sensitivity of the receiver, the output power difference among the four wavelength signals needs to be small. According to the market demand, a gain difference of 4 dB or less was targeted.

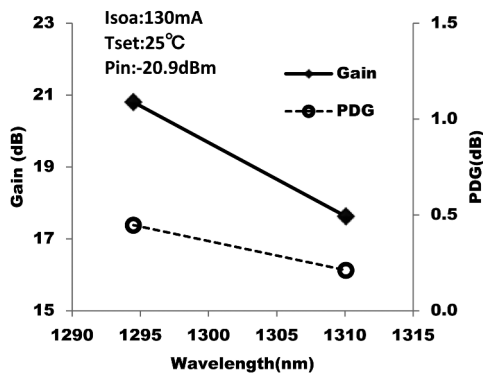

Fig. 7. Signal wavelength dependence of gain/PDG

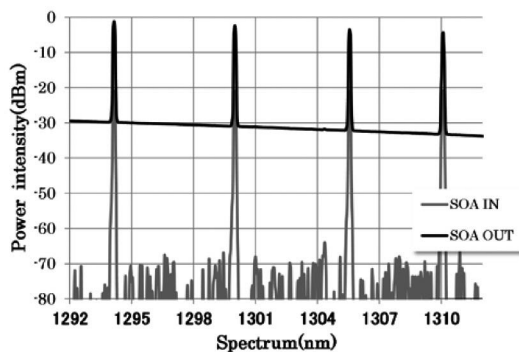

Fig. 8. Spectrum as simultaneous input signal

Spectra before and after the simultaneous amplification are shown in Fig. 8. The evaluation conditions are: the SOA current is 130 mA, the operating temperature is 25 deg. C, and the input signal power is -20.9 dBm. A gain difference among the four channels was confirmed to be 3.5 dB. Therefore the SOA achieved the target value (4 dB or less).

5. Characteristics-2 (Optical wave form / Transmission performance)

The 25 Gbit/s optical waveforms with and without the SOA are shown in Fig. 9. The optical signal was attenuated down to -20.9 dBm by an optical attenuator and amplified by the SOA to the same level before attenuation. Waveforms are observed by the optical plug-in module of an oscilloscope with Bessel-Thompson filter. Although the amplified optical waveform has an increased on-level noise level, the change of the extinction ratio (ER) was as small as 0.3 dB.

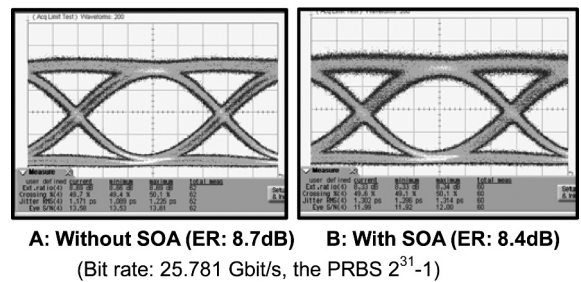

Fig.9. Optical waveform in SOA (Without / With)

Next, the 25 Gbit/s transmission penalties with and without the SOA were evaluated. The 25 Gbit/s transmitter optical sub assembly (TOSA) and receiver optical sub assembly (ROSA) used in the evaluation test were STN41QD and SPG72FV manufactured by Sumitomo Electric Device Innovations, Inc. (SEDI).

The evaluation results for the minimum sensitivity with and without the SOA are shown in Fig. 10.

The condition of the input signal is the same as that of the optical waveform evaluation. Signal wavelength is 1295.60 nm (L0). The SOA module was driven at a current of 55 mA and an operating temperature of 25 deg. C.

The improvement in the minimum receiver sensitivity with the SOA was confirmed to be 9.6 dB. (The minimum receiver sensitivity was -13.2 dbm without the SOA and -22.8 dBm with the SOA.)

It was confirmed that the SOA module achieved a minimum receiver sensitivity of -21.4 dBm, complying with the 100GBASE-ER4 standard (-21.4 dBm) when used with SEDI's TOSA/ROSA.

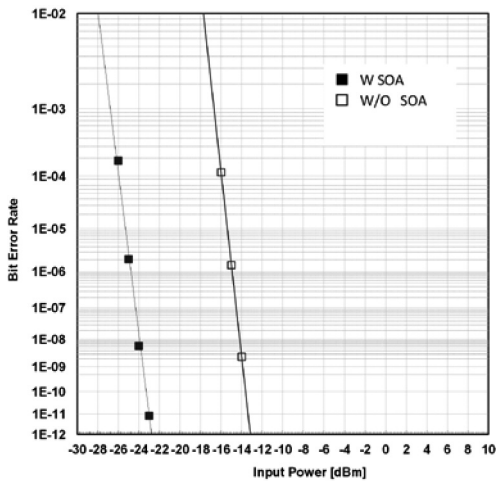

Fig. 10. Transmission performance

6. Reliability

We conducted a high-temperature aging test for the SOA module and a high-temperature operation test for the SOA chip. The result of the high temperature ageing test is shown in Fig. 11 and that of the high temperature operation SOA chip ageing test is shown in Fig. 12. The variation of both ageing tests are within +/-1 dB.

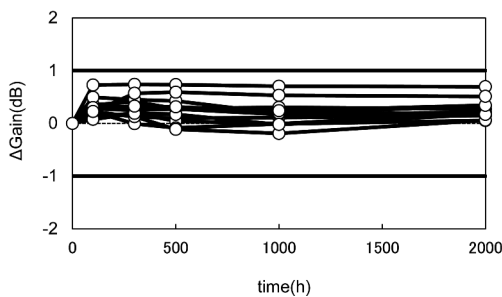

Fig. 11. High-temperature ageing test result

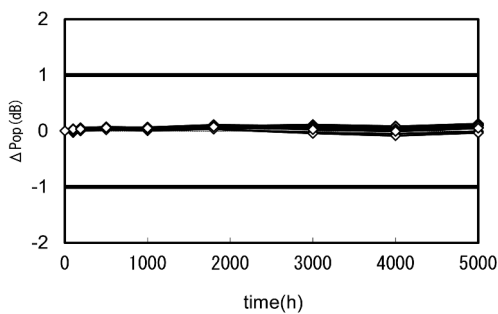

Fig. 12. SOA chip ageing test result

From the test results, the total failure rate of the SOA module is estimated to be about 20 fits after 10 years and about 200 fits after 20 years. These estimations were conducted at a case temperature of 50 deg. C, SOA current of 150 mA and SOA operating temperature of 25 deg. C.

The reliability of the SOA module is equivalent to that of the existing optical communication device. Additionally the SOA module passed the tests according to Telcordia GR-468-Core. Therefore it was confirmed that the SOA module has reliability sufficient for optical communication applications.

7. Conclusions

We have developed a small SOA module for 100 Gbit/s CFP optical transceivers. By optimizing the optical coupling system and components used, its module size was reduced. The module uses tight bending optical fiber for better flexibility of transceiver assembly. This new SOA module satisfies the requirements for four channel LAN-WDM 40 km transmission as a small size optical amplifier.

• PureAccess is a trademark of Sumitomo Electric Industries, Ltd.

Reference

- (1) Eiji Tsumura et al., "Development of 43/112 Gbit/s Optical Transceiver Modules," SEI Technical Review, No. 75 (Oct. 2012)

Contributors (The lead author is indicated by an asterisk (*).)

R. TERANISHI*

- Light wave Devices Development Department, Sumitomo Electric Device Innovations, Inc.

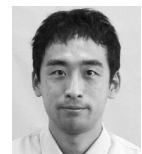

Y. YAMAUCHI

- Assembly and Test Technologies Department, Sumitomo Electric Device Innovations, Inc.



Y. FUJIHARA

- Light wave Device Process Development Department, Sumitomo Electric Device Innovations, Inc.



S. KANEMARU

- Assembly and Test Technologies Department, Sumitomo Electric Device Innovations, Inc.



T. ABE

- Ph. D.

Group Manager, Light wave Devices Development Department, Sumitomo Electric Device Innovations, Inc.



K. SATOH

- General Manager, Light wave Devices Development Department, Sumitomo Electric Device Innovations, Inc.

