

Highly Durable Ultra-high Strength Prestressing Strand System with Large Diameter

Katsuhito OSHIMA*, Shuichi TANAKA, Shinji NAKAUE, Motonobu NISHINO, Yoshiyuki MATSUBARA and Masato YAMADA

Sumitomo (SEI) Steel Wire Corp. developed an epoxy coated and filled 15.7 mm ultra-high strength prestressing (UHSP) strand consisting of 7 wires. The UHSP strand is approximately 20% stronger (2,230 MPa) than the conventional strand (1,860 MPa). Through its experience and expertise, the company has recently developed large-diameter UHSP strands: a 29.0 mm 19-wire strand and 17.8 mm 7-wire strand. These strands prevent delayed fracture by the epoxy or high-density polyethylene coating, and thus contribute to high-durability concrete bridges. This paper describes the features of the 29.0 mm 19-wire UHSP strand with pre-grout tendons and epoxy coated and filled 17.8mm 7-wire UHSP strand.

Keywords: prestressing strand, high strength, high durability

1. Introduction

A prestressing*¹ strand is a steel product used to reinforce concrete. By applying a compressive force to a concrete structure, the strand adds tensile strength to the concrete. In addition to prestressing strands, Sumitomo Electric Industries, Ltd. provides all-inclusive prestressing strand systems, including: anchorages that maintain prestressing strands under tension; anchorage systems and products such as plates used to transfer compressive force to concrete, as well as reinforcing bars; and tension devices and other installation equipment.

In recent years, in the civil engineering sector, there has been a growing demand for concrete bridges to be highly durable, resource saving, labor saving, and less environmentally damaging. To meet this demand, Sumitomo Electric has promoted the application and deployment of prestressing strand coating and strength improvement technologies. For example, epoxy coated and filled (ECF) 15.7 mm ultra-high strength prestressing (UHSP) strands and 15.2-28.6 mm pre-grout (PRG) tendons have already been used on many bridges. This paper is on a 29.0 mm PRG UHSP strand system and a 17.8 mm ECF UHSP strand system newly developed by Sumitomo Electric using its own coating and strength improving technologies.

2. ECF UHSP and PRG Strands

2-1 Current status of 15.7 mm ECF UHSP strands

The 15.7 mm ECF UHSP strand has a tensile strength of 2,230 MPa, which is 20% higher than that of the 15.2 mm strand (1,860 MPa) specified in the Japanese Industrial Standards Committee (JIS) G 3536. This was achieved by using carbon and silicon as additives (Table 1) to the piano wire specified in JIS (JIS G 3502: SWRS82B) and optimizing drawing techniques and hot stretching*² conditions used in the stranding process. This prestressing strand has been made free of

the problems of susceptibility to scratches and delayed fracture specific to high-strength steel by providing epoxy coating on the inside and outside surfaces of the strand (Photo 1). The key features of prestressed concrete structures that use UHSP strands are:

- 1) Labor-saving installation and maintenance
- 2) Adaptability to fast installation
- 3) Reduced environmental burden by reduced use of materials (energy saving and reduction of CO₂, SO_x, and NO_x emissions during manufacture and transportation)
- 4) Enables lightweight, slender and strong prestressed concrete structures
- 5) Enhanced cable placement flexibility

These features have allowed the UHSP strands to be adopted for more than 16 projects, principally as bridge outer cables (Fig. 1) since the company developed the product in 2004. Incidentally, 15.2 mm and smaller ECF strands are standardized in the "Recommendations for Design and Construction of Prestressed Concrete Structures Using Advanced Prestressing Steel Coated by Epoxy Resin (Draft), Japan Society of Civil Engineers⁽¹⁾" (hereinafter, the "JSCE Guidelines"). In addition, 15.7 mm and smaller UHSP strands are standardized in the "Recommendations for Design and Construction of Prestressed Concrete Structures Using Ultra-high Strength Prestressing Steel⁽²⁾" (hereinafter, the "UHSP Steel Guidelines").

Table 1. Chemical composition of UHSP strands (wt%)

	Carbon	Silicon	Manganese	Phosphorus	Sulfur	Copper
UHSP strand	0.95-1.02	0.85-1.50	0.30-0.50	0.024 max.	0.01 max.	0.15 max.
Reference: SWRS 82B (JIS G3502)	0.80-0.85	0.12-0.35	0.60-0.90	0.025 max	0.025 max	0.20 max

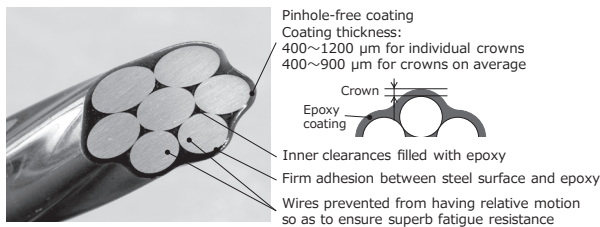

Photo 1. Features of ECF strand

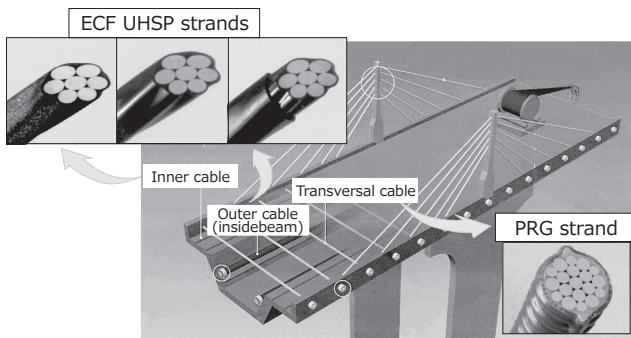

Fig. 1. Typical applications of ECF UHSP and PRG strands

2-2 Features of PRG strand

A PRG strand is produced by molding through a continuous extrusion in which high-density polyethylene is extruded over uncured epoxy applied to the surface of a prestressing strand. As the applied epoxy cures with time, the strand will be eventually integrated with concrete due to the raised-and-recessed (ribbed) surfaces of the high-density polyethylene. Thus, the PRG strand is a corrosion-proof prestressing strand that saves the need for grouting (injection of cement slurry into gaps between sheath and prestressing strand) and sheath placement on construction sites (Fig. 2). This product has been increasingly used since 1990. Factors involved in this increased use include the development by Sumitomo Electric of a moisture-curable resin, which

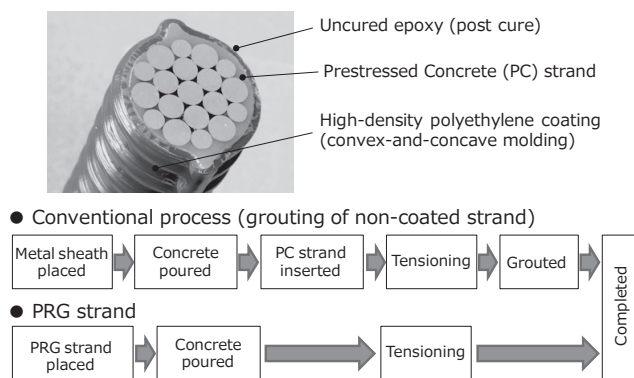

Fig. 2. Features of PRG strand

is, unlike conventional thermosetting resin and as an improved alternative to epoxy resin, resistant to the effect of concrete hydration heat, along with the standardization of it in the JSCE Guidelines.⁽¹⁾ Since 2010 to present, PRG strands have been used as a general-purpose transverse prestressing cable in about 500 projects and as a longitudinal bridge cable in 18 projects.

3. 29.0 mm PRG UHSP Strand

In response to the growing need for improved strength, Sumitomo Electric has developed an extra-thick 19-wire PRG UHSP strand (29.0 mm). This strand is approximately 20% higher in both the maximum test load and the load relative to 0.2% permanent elongation than the 19-wire prestressing strand (28.6 mm, SWPR19L) specified in JIS as the highest capacity single strand. While PRG strands have been conventionally used typically as transverse stressing cables (Fig. 1), the newly developed product is expected to pave the way for use of PRG strands in the main direction (longitudinal) of concrete members (Fig. 3). The following sections report on the development of the 29.0 mm PRG UHSP strand and of the anchorage system for it, along with the results of performance verification tests.

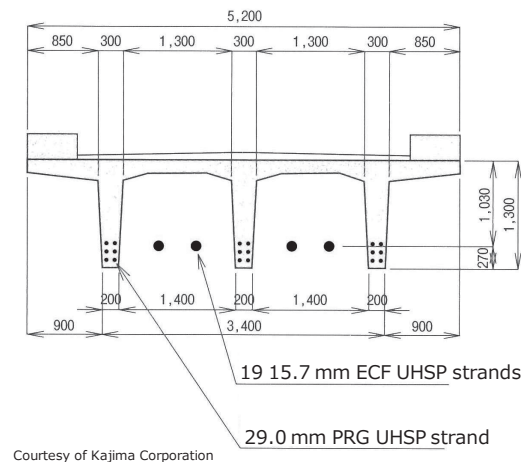

Fig. 3. Example application of 29.0 mm PRG UHSP strand

3-1 Properties of 29.0 mm uncoated strand

Table 2 shows the mechanical properties of the 29.0 mm UHSP strand. Although the UHSP Guidelines⁽²⁾ provide standards for 19-wire UHSP strands, their maximum test load is only 10% to 15% better than JIS-compliant products. In contrast, the 29.0 mm UHSP strand has a 20% higher maximum test load than specified in JIS. This was achieved by applying the strength improvement technology used to produce the aforementioned 15.7 mm ECF UHSP strand. The following descriptions detail tensile and relaxation^{*3} properties, as well as delayed-fracture properties that are a matter of

concern due to degraded properties resulting from strength improvement.

Table 2. Mechanical properties of 29.0 mm PRG UHSP strand

	Strand diameter (mm)	Maximum test load (kN)	Load relative to 0.2% permanent elongation (kN)	Elongation (%)	Relaxation value (%)
29.0 mm UHSP strand (Voluntary standards)	29.0 +0.6, 0.25	≥ 1139	≥ 996	≥ 3.5	≤ 2.5
Reference : 28.6 mm UHSP strand (UHSP Guidelines)	28.6 +0.6, -0.25	≥ 1044	≥ 888		
Reference : 28.6 mm strand (JIS G3536: SWPR19L)		≥ 949	≥ 807		

(1) Tensile and relaxation test results

Table 3 shows the results of tensile and relaxation tests conducted on the 29.0 mm UHSP strand. Both the maximum test load and the load relative to 0.2% permanent elongation were higher than the loads specified in JIS by a factor of greater than 1.2. The 29.0 mm UHSP strand exhibited a value of elongation at a similar level to JIS-compliant products, implying that the strand bears comparison in tenacity with standard JIS-compliant products. Moreover, after testing for 1,000 h, the strand exhibited a relaxation value of 0.99%, which fulfills the standard (2.5% max.) specified in JIS G 3536 for low-relaxation products.

Table 3. Tensile and relaxation test results (example)

	Maximum test load (kN)	Load relative to 0.2% permanent elongation (kN)	Elongation (%)	Relaxation value (%)
29.0 mm UHSP strand	1161	1030	5.7	0.99
Reference : 28.6 mm strand (JIS G3536: SWPR19L)	972	886	5.3	1.52

(2) Delayed-fracture resistance test

The delayed-fracture resistance test measures the time before break of the center wire under an 80% load of the maximum testing force in an ammonium thiocyanate solution [NH₄SCN (20 wt%)] at 50°C in accordance with the UHSP Guidelines.⁽²⁾ Table 4 shows the results of the delayed-fracture resistance test

Table 4. Results of delayed-fracture resistance test (example)

	1	2	3	4	5	6	Minimum value (≥ 1.5h)	Cumulative breakage probability of 50%
Time before breakage (h)	11.0	14.2	15.6	17.5	18.4	22.4	11.0	16.6

conducted on the 29.0 mm UHSP strand. This strand fulfilled the specifications provided in the UHSP Guidelines,⁽²⁾ which are a minimum measurement of 1.5 h or more and a time before break of 4 h or more at the cumulative breakage probability of 50%.

3-2 Pre-grouted 29.0mm UHSP strand

Sumitomo Electric provides factory-made corrosion resistance, in principle, for all UHSP strands used in practical applications, in light of the susceptibility of strands to scratches and delayed fracture. The 29.0 mm PRG UHSP strand is provided with the pre-grouting specified in the JSCE Guidelines.⁽¹⁾ Accordingly, this product has superb corrosion resistance that passes 1,000 h salt spray testing (JIS Z 2371) and alkali resistance testing (ASTM G20).

(1) Strand geometry after pre-grouting

Figure 4 shows strand geometry after pre-grouting. Compared with the geometry of a conventional 28.6 mm PRG strand, the 29.0 mm PRG UHSP strand has the same diameter difference between raised and recessed sections, which affects adhesion characteristics, and the same thickness of resin coating over the raised sections, which affects corrosion resistance. The outside diameters of the raised and recessed sections of the 29.0 mm PRG UHSP strand are slightly greater than those of the 28.6 mm PRG strand.

Parameters	29.0 mm PRG UHSP strand	Conventional 28.6 mm PRG strand
Diameter difference between convex and concave part	≥ 0.5 mm	Same as left
Coating thickness of convex part	≥ 1.2 mm	Same as left
Diameter of convex part	34.0-40.0 mm	34.0-38.0 mm
Diameter of concave part	30.0-35.5 mm	30.0-33.5 mm
Ribs diameter	≤ 45 mm	Same as left

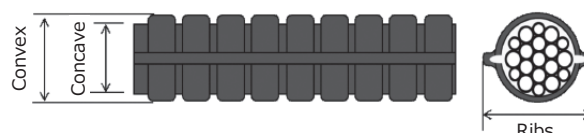

Fig. 4. Strand geometry after pre-grouting

(2) Bond test

A bond test was conducted on PRG strands, as specified in the JSCE Guidelines.⁽¹⁾ Table 5 shows the test results. The tested PRG strands fulfilled the requirement, exhibiting bond strength at the same level as or higher than the 29.0 mm in situ-grouted, uncoated UHSP strands.

Table 5. Bond test results (example)

	Bond strength (N/mm ²)
29.0 mm PRG UHSP strand	6.9
29.0 mm in situ-grouted UHSP strand	6.2

3-3 Anchorage system for single 29.0 mm PRG UHSP strand

Figure 5 shows the single anchorage system (barrel and wedge) designed for the newly developed 29.0 mm PRG UHSP strand. The results of a performance verification test conducted using this anchorage system are shown below.

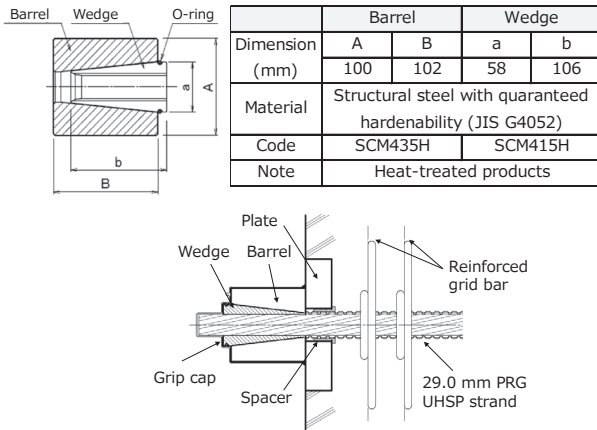

Fig. 5. Anchorage system for 29.0 mm PRG UHSP strand

(1) Tensile test of grips in conjunction with tendon

The anchorage efficiency of grips was measured by the static tensile test specified in the “Standard Specifications for Concrete Structure, Japan Society of Civil Engineers⁽³⁾” (hereinafter, the “Standard Specifications for Concrete Structure”). The test results fulfilled the requirement of at least 95% of the maximum test force, being at 99.7%.

(2) Fatigue test of grips in conjunction with tendons

A fatigue test was conducted in accordance with the “Recommendations for the acceptance of post-tensioning systems (1993), FIP⁽⁴⁾” (hereinafter, the “FIP Specifications”), i.e. an upper load limit of 0.65 Pu (Pu: maximum test force), a stress fluctuation range of 80 MPa, and a number of loading cycles of two million. The tested fittings and tendons exhibited sufficient durability, remaining unbroken even after two million loading cycles.

(3) Other specifications for anchorage systems

The standard specifications for cable placement intervals, reinforced grid bars, and bearing plates of the anchorage system were determined through the concrete load transfer test specified in the Standard Specifications for Concrete.⁽³⁾ We developed jacks and jack wedges as tensioning devices specialized for the 29.0 mm PRG strand to verify the durability of the anchorage system through a repeated tensioning test. Furthermore, a range of engineering matters required for design and installation have been checked, including measurement of set amount (7 mm) and protective caps for grips.

4. 17.8 mm ECF UHSP Strand

Polyethylene (PE) sheaths and corrosion-proof prestressing steel are occasionally used to improve the durability of transverse prestressing cables for precast beams involving poured-in-place sections (e.g. inter-filling sections). In such cases, it may be necessary to make a cross-sectional modification to slabs depending on the details of sheath connections and increases in sheath outside diameter. With this in mind and with an aim to achieve multiple corrosion-proof measures by the combined use of PE sheath, cement grout, and corrosion-proof prestressing steel without making any cross-sectional change to a construction member, we have newly developed a 17.8 mm 7-wire ECF UHSP strand (Fig. 6). The 7-wire configuration was intended to fulfill the applicable ECF strand requirements specified in the JSCE Guidelines⁽¹⁾ by ensuring that epoxy resin is filled between the steel wires. Meanwhile, drawing on Sumitomo Electric’s high-strength technology, the 17.8 mm 7-wire strand withstands a maximum testing force (tensile force) comparable to, or better than, that of the 17.8 mm 19-wire strand specified in the applicable current JIS (JIS G 3536) (Photo 2). The development of the 17.8 mm ECF UHSP strand and its compatible anchorage system as well as the results of performance verification tests conducted on them are reported below.

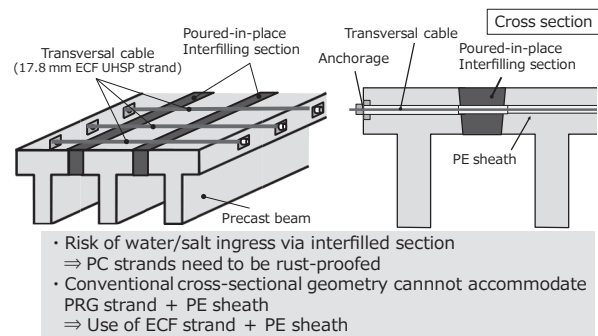

Fig. 6. Example application of 17.8 mm ECF UHSP strand

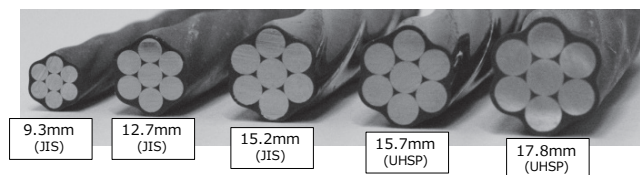

Photo 2. Appearance of ECF strands

4-1 Properties of uncoated 17.8 mm strand

Table 6 shows the mechanical properties of the 17.8 mm UHSP strand. The 17.8 mm UHSP strand is approximately 15% higher in tensile strength than the conven-

tional 17.8 mm strand owing to the application of the aforementioned high-strength technology. This 7-wire strand is smaller in the cross section of steel than the 17.8 mm 19-wire strand. However, its improved strength allows the 17.8 mm UHSP strand to exhibit greater maximum test load and load relative to 0.2% permanent elongation than the conventional 17.8 mm 19-wire prestressing steel strand.

Table 6. Mechanical properties

	Maximum test load		Load relative to permanent elongation 0.2%		Elongation (%)	Nominal cross-sectional area (mm ²)
	(kN)	(N/mm ²)	(kN)	(N/mm ²)		
17.8 mm 7-wire UHSP strand (Voluntary standards)	≥ 387	≥ 2037	≥ 330	≥ 1737	≥ 3.5	190.0
Reference : 17.8 mm 19-wire strand (JIS G3536: SWPR19L)		≥ 1857		≥ 1583		208.4

(1) Tensile test

Table 7 shows the results of a tensile test conducted on the 17.8 mm UHSP strand. The strand fulfilled the mechanical property requirements (voluntary standards) specified in Table 6. The value of elongation was at a similar level to that of JIS-compliant products. Thus, the 17.8 mm UHSP strand offers improved strength without compromising tenacity.

Table 7. Tensile test results (example)

	Maximum test load (kN)	Load relative to 0.2% permanent elongation (kN)	Elongation (%)
17.8 mm 7-wire UHSP strand	422	377	7.1
Reference : 17.8 mm 19-wire strand (JIS G3536 : SWPR19L)	400	365	6.5

(2) Delayed-fracture resistance test

Table 8 shows the results of a delayed-fracture resistance test. The 17.8 mm UHSP strand fulfilled the applicable standards of a minimum time before break of 1.5 h or more and a time before break of 4 h or more at the cumulative breakage probability of 50%.

Table 8. Results of delayed-fracture resistance test (example)

	1	2	3	4	5	6	Minimum value (≥ 1.5h)	Cumulative breakage probability of 50%
Time before breakage (h)	6.6	6.7	8.7	9.5	10.5	12.5	6.6	9.1

(3) Fatigue test

A fatigue test was conducted on the prestressing steel in accordance with the UHSP Guidelines,⁽²⁾ i.e. an

upper load limit of 0.70 Pu (Pu: maximum test load), a stress fluctuation range of 195 MPa, and a number of loading cycles of two million. The tested prestressing steel remained unbroken.

(4) Deflected tensile test

A deflected tensile test was conducted in accordance with the UHSP Guidelines⁽²⁾ at a bending angle of 20°. The test results were satisfactory (e.g. 17.5%) in comparison with the specified maximum percent relaxation of 28%.

4-2 Properties of 17.8 mm ECF UHSP strand

The 17.8 mm ECF UHSP strand has an average crown coating thickness of 0.4-0.9 mm, with the coating thickness of individual crowns ranging from 0.4 to 1.2 mm. The high corrosion-resistant epoxy coating compliant with the JSCE Guidelines⁽¹⁾ is free of pinholes over the entire length.

(1) Relaxation test

The results of the relaxation test indicated a 1,000 h relaxation estimate of 3.3%, fulfilling the 6.5% limit specified in the JSCE Guidelines.⁽¹⁾

(2) Coating adhesion test

A coating adhesion test was conducted in accordance with “Test method for epoxy coated and filled strand for prestressed: Adhesion of epoxy coating” (JSCE-E 731). Photo 3 shows the results of a bending test and a tensile breaking test. The bending test was conducted by winding the strand by 180° around a cylinder 32 times larger in diameter than the nominal diameter of the strand and at a temperature of 20±2°C. The test specimen developed no damage to the epoxy coating and no pinhole was observed. In the tensile breaking test, the coating exhibited superb adhesion without developing any exfoliation or scattering near the broken section despite the strong shock at break.

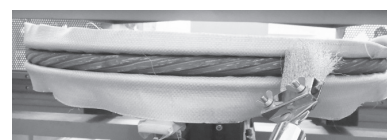

(a) Bending test



(b) Appearance of strand after tensile breaking test

Photo 3. Coating adhesion test (example)

(3) Bond test

An ECF strand bond test was conducted as specified in the JSCE Guidelines.⁽¹⁾ The test results showed that the bond strength of the 17.8 mm ECF UHSP strand was comparable to or better than that of the 17.8 mm uncoated UHSP strand.

Table 9. Bond test results (example)

	Bond strength (N/mm ²)
17.8 mm ECF UHSP strand	0.97
17.8 mm uncoated UHSP strand	0.81

(4) Impact resistance test

The impact resistance test (test method: ISO 6272) specified in the JSCE Guidelines⁽¹⁾ was conducted. The results showed no abnormalities such as cracks and exfoliation in the epoxy coating outside the range of permanent deformation, displaying sufficient impact resistance to fulfill the JSCE Guidelines.⁽¹⁾

4-3 Anchorage system for single 17.8 mm ECF UHSP strand

Figure 7 shows the single anchorages (barrel and wedge) and the anchorage system designed for the newly developed 17.8 mm ECF UHSP strand.

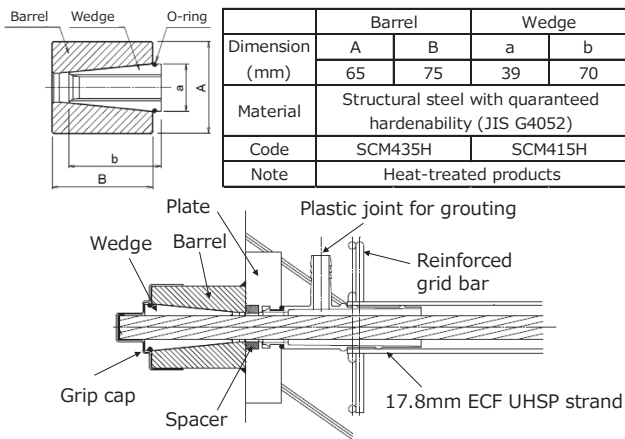

Fig. 7. Anchorage system for 17.8 mm ECF UHSP strand

(1) Tensile test of grips in conjunction with tendon

The anchorage efficiency of anchorages was measured by the static tensile test specified in the Standard Specifications for Concrete.⁽³⁾ The test results fulfilled the requirement of at least 95% of the maximum test load, being at 107.7% (example).

(2) Fatigue test of grips in conjunction with tendon

A fatigue test was conducted in accordance with the FIP Specifications.⁽⁴⁾ The steel exhibited sufficient durability, remaining unbroken even after two million loading cycles.

(3) Concrete load transfer test of anchorage system

The standard specifications for cable placement intervals, reinforced grid bars, and bearing plates of the anchorage system were determined through the concrete load transfer test specified in the Standard Specifications for Concrete.⁽³⁾ Furthermore, a range of engineering matters required for the design and instal-

lation of the system have been checked, including measurement of set amount (12 mm) and tensioning devices.

(4) Wear resistance of ECF UHSP strand subjected to abrasion with PE sheath

The ECF UHSP strand was arranged to move over a PE sheath in accordance with "Recommendations for Design and Construction of Prestressed Concrete bridges Using polyethylene duct (Draft)⁽⁵⁾" at a temperature of 50°C with the prestressing steel receiving an internal pressure assuming the minimum cable bending radius (100 D: strand diameter) and a tensile force of 0.7 Pu. Table 10 shows the remaining thickness of the sheath after the test. The remaining sheath thickness was greater than the 1.5 mm limit. After the test, no decrease was observed in the coating thickness of the ECF UHSP strand, proving that this strand has favorable wear resistance in abrasion with PE sheath.

Table 10. Wear resistance test results (example)

		Remaining thickness (mm) ≥ 1.5mm (Specification)		
		1	2	3
PE sheath manufacturer	Company A	2.06	2.04	2.01
	Company B	1.88	1.80	1.86
	Company C	1.70	1.86	1.52

5. Conclusion

Sumitomo Electric has newly developed a 29.0 mm pre-grout (PRG) ultra-high strength prestressing (UHSP) strand system and a 17.8 mm ECF UHSP strand system with higher strength and corrosion resistance than the prestressing strands specified in JIS. These newly developed systems have been verified to pass various performance tests. The first shipping of the 29.0 mm PRG UHSP and 17.8 mm ECF UHSP strand has already taken place.

We are working on the additional development of a 21.8 mm ECF UHSP strand and hope that these newly developed products will be used widely to help extend the life of structures and reduce their life cycle costs.

Technical Terms

- *1 Prestressing: A method of overcoming the weakness of concrete in tension by producing a compressive stress in concrete.
- *2 Hot stretching: A heating and cooling process for reinforcing stranded wires under tension; The principal purposes of hot stretching are to improve the relaxation properties and yield point.
- *3 Relaxation: The phenomenon of stress relaxation with time under constant strain.

References

- (1) Japan Society of Civil Engineers (2010), Recommendations for Design and Construction of Prestressed Concrete Structures Using Advanced Prestressing Steel Coated by Epoxy Resin (Draft)
- (2) Japan Prestressed Concrete Engineering Association (2011), Recommendations for Design and Construction of Prestressed Concrete Structures Using Ultra-high Strength Prestressing Steel
- (3) Japan Society of Civil Engineers (2012), Standard Specifications for Concrete Structure
- (4) FIP (1993), Recommendations for the Acceptance of Post-tensioning Systems
- (5) Japan Prestressed Concrete Institute (2015), Specification for Design and Construction of PC Bridge Using PE Sheath

Contributors The lead author is indicated by an asterisk (*).

K. OSHIMA*

- Senior Engineer, PC Technical Department, Sumitomo (SEI) Steel Wire Corp.



S. TANAKA

- PC Technical Department, Sumitomo (SEI) Steel Wire Corp.



S. NAKAUE

- PC Technical Department, Sumitomo (SEI) Steel Wire Corp.



M. NISHINO

- Group Manager, PC Technical Department, Sumitomo (SEI) Steel Wire Corp.



Y. MATSUBARA

- Group Manager, PC Technical Department, Sumitomo (SEI) Steel Wire Corp.



M. YAMADA

- Senior Specialist Director, Sumitomo (SEI) Steel Wire Corp. Manager, PC Technical Department

