

A 10G-EPON Optical Line Terminal for Replacing 1G-EPON System and Reducing Operational Expenditure

Hiroyuki SHIMIZU*, Tomoyuki FUNADA, Minoru DAIMA, Hiroyuki TAKAHASHI, Naoki YOSHITANI, and Hiroshi MURATA

We have been developing communication equipment based on passive optical network (PON) technology to promote the widespread use of fiber-to-the-home (FTTH) broadband services domestically and globally. To accommodate the data traffic that has been increasing due to high-quality video distribution, we have developed a 10 Gigabit Ethernet PON (10G-EPON) optical line terminal (OLT) that supports nearly ten times higher line-speed transmission than the current Gigabit Ethernet PON (1G-EPON). This paper presents the 10G-EPON OLT that supports upcoming features of broadband video services, such as 4K and 8K resolutions, using existing optical distribution networks and optical network units (ONU) for 1G-EPON. It also reports on the lower size and power consumption of the 10G-EPON OLT, which will reduce operational expenditures.

Keywords: FTTH, 10G-EPON, 1G-EPON, optical Internet access

1. Introduction

The total download traffic by broadband subscribers in Japan is increasing by about 50% annually due to, for example, wider use of video streaming services using smartphones and tablets.⁽¹⁾ In addition, with the coming of the IoT society, a large number of various devices will be connected to the network and communication traffic will increase further.

In fixed broadband services, there were 29 million FTTH access lines as of end-December 2016,⁽²⁾ of which many use a 1G-EPON system with a maximum bandwidth of 1 Gbit/s. We have been selling optical line terminals (OLTs) and optical network units (ONUs) to telecommunication carriers both in Japan and abroad since 2005 when we launched a 1 Gigabit Ethernet PON (1G-EPON*) communication system.

In recent fixed broadband services, not only data services (Internet) but also other services, such as voice with different communication quality (telephone), video (TV broadcast and video on demand), and services for business, are constantly provided and play a key role as social infrastructure. Particularly for video services, along with the progress in high-definition video technology from 2K to 4K/8K video, the video data bandwidth is increasing significantly. In addition, since it is necessary to support multi-channel broadcasting services, there are high expectations for a 10G-EPON system, which has about 10 times higher access line speed than the existing 1G-EPON system, to stably distribute large quantities of video data and support service expansion in the future.

We have been developing elemental technologies and equipment for 10G-EPON since fiscal 2006 and recently commercialized 10G-EPON OLT, which is reported here.

2. Requirements for OLT and the System Structure

2-1 Requirements

To commercialize the new OLT, the following requirements were taken into consideration for development:

(1) Higher access line speed

For the distribution of 4K and 8K video, respective bandwidths of about 30 Mbit/s and 100 Mbit/s are required. In order to support multi-channel distribution of such high-definition video, 10G-EPON having about 10 times higher access line speed than the existing system and being highly compatible with the existing 1G-EPON was adopted.

(2) Ease of shifting to high-speed access lines

In the PON system, the OLT installed on the telecommunication office (Central Office) is connected to the ONU on the subscribers' side via an optical fiber access network. Building a new access network for 10G-EPON in addition to the existing network for 1G-EPON would be a significant investment burden for telecommunication carriers and hinder a smooth shift to a high-speed access network. Furthermore, in the process of shifting to high-speed access lines, the existing lines will still be needed. Accordingly, 10G-EPON OLT was designed so that it can use the existing access network for 1G-EPON and both the ONU for 1G-EPON and the ONU for 10G-EPON can be accommodated together on the same access line.

(3) Reducing operational expenditure

For the development of broadband services, communication equipment and networks are important social infrastructure, and therefore it is necessary to meet the social need for lower operational expenditure. A 10G-EPON OLT was developed with a focus on reducing operational expenditure as follows:

(a) Reducing the number of types of OLT

(b) Reducing the number of OLTs installed (increasing the number of subscribers per OLT)

(c) Reducing the installation space

(d) Reducing the power consumption network

(4) Improving OLT reliability

If the number of subscribers per OLT is increased in order to reduce operational expenditure, more subscribers may be affected in case of a fault. For 10G-EPON OLTs, in order to improve the OLT reliability, redundancy was secured to allow services to continue for subscribers even if some OLT functions were stopped in case of a fault. In addition, a common interface for managing the redundancy function was provided for OLT operators to facilitate operation.

2-2 System structure

For 10G-EPON OLTs, an optical interface whereby 1G-EPON and 10G-EPON can coexist at the line accommodation section was adopted. This optical interface was designed to be hot-pluggable to allow flexibility for extension or replacement work after the start of system operation. In addition, the network structure was simplified and included a line concentration function to bundle multiple PON access lines in order to reduce operational expenditure by saving space and power consumption. Furthermore, components with low power consumption were chosen to allow high-density mounting.

Since the system included a line concentration section, the number of subscribers was increased because they could be accommodated in the line concentration section and the uplink port connecting this OLT to the equipment in the core network. Accordingly, fault tolerance is ensured in order to support the redundancy function of the line concentration section and the uplink port.

For setting each functional section and managing, for example, faults and the redundancy function, Sumitomo Electric optical fiber access system integration architecture (sOFIA), which has a proven track record as a common software platform for our optical network equipment, was adopted to improve development efficiency and quality.⁽³⁾

3. Application Effect of 10G-EPON

3-1 Increasing the data rate to 10 Gbit/s

In IEEE 802.3 standards,⁽⁴⁾ operation of the existing 1G-EPON along with newly introduced 10G-EPON was taken into consideration to determine the wavelength allocation as shown in Fig. 1. By using wavelength division multiplexing (WDM^{*2}) for 1G-EPON and 10G-EPON in the downstream direction (from OLT to ONU) and time division multiplexing (TDM^{*3}) for 1G-EPON and 10G-EPON in the upstream direction, coexistence and simultaneous operation were made possible (Fig. 2). If the operational specifications are selected whereby the upstream wavelength of 1G-EPON does not overlap the

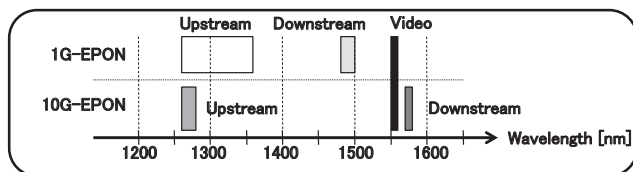

Fig 1. Wavelength allocation for EPON

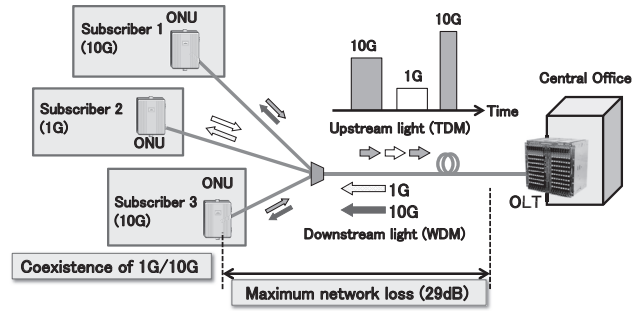

Fig 2. 10G-EPON system structure

upstream wavelength of 10G-EPON (for example, if the upstream wavelength of 1G-EPON is allocated between 1290 and 1330 nm), the respective systems dedicated to 1G-EPON and 10G-EPON can be independently operated as they can coexist using WDM.

The PON optical interface of this OLT supports 1000BASE-PX30 and 10GBASE-PR30 specified in IEEE802.3 standards with a maximum network loss of 29 dB, assuming a reach of at least 20 km and a split ratio of at least 1:32 (Table 1).

Table 1. PON optical interface specifications

Parameter	Downstream		Upstream		Unit	
	PR30	PX30	PR30	PX30		
Line rate	10.3125	1.25	10.3125	1.25	Gbit/s	
Wavelength	1575-1580	1480-1500	1260-1280	1260-1360	nm	
Maximum distance	≥ 20	≥ 20	≥ 20	≥ 20	km	
Maximum line insertion loss	29	29	29	29	dB	
Tx	Average launch power	2-5 *	3-7 **	4-9 **	0.62-5.62 **	dBm
	Extinction ratio	≥ 6	≥ 6	≥ 6	≥ 6	dB
	TDP	≤ 1.5	≤ 1.0	≤ 3.0	≤ 1.4	dB
Rx	Bit error rate	≤ 10 ⁻³	≤ 10 ⁻¹²	≤ 10 ⁻³	≤ 10 ⁻¹²	—
	Average receive power	-10 to -28.5	-8 to -27	-6 to -28	-9.38 to -29.78	dBm

* Extinction ratio 9dB ** Extinction ratio 6dB

If the ONUs of 1G-EPON and 10G-EPON are accommodated together using the same OLT, the multi-point control protocol (MPCP^{*4}) of the OLT controls upstream TDM and manages the transmission timing of each ONU. Equipped with a rate selection function whereby the electrical bandwidth of receivers can be switched to either of the electrical bandwidth for 1G-EPON or 10G-EPON corresponding to the upstream signal arrival time from each ONU in cooperation with the MPCP, this OLT optimally adjusts receivers for the respective electrical bandwidth and thus achieves high receiver sensitivity even when two types of ONUs coexist.

In addition, the new ONU connected to the PON system can be automatically discovered by the MPCP of the OLT and registered; this process is called the discovery

process. Although upstream TDM control is necessary even for the discovery process, performing this process for each ONU at the respective periods of time makes it possible to optimally set the electrical bandwidth of receivers during the respective discovery periods. Thus, high receiver sensitivity is achieved even in the discovery process while the two types of ONUs coexist.

The PON optical interface must be hot-pluggable to allow flexible operation, including extension or replacement work after the start of system operation. For this OLT, an industry-standard size optical transceiver called XFP (10 Gbit/s small form factor pluggable)⁽⁵⁾ was developed.⁽⁶⁾

The optical transceiver used for this OLT has to support the transmission and reception of both 1G-EPON and 10G-EPON with a single unit, and it was a challenge to reduce its size. The transmission side transmits the signal light of 1490 nm at 1 Gbit/s, which is the downstream signal of 1G-EPON, and the downstream signal light of 1577 nm at 10 Gbit/s using WDM. The reception side receives the time division multiplexed burst signal light consisting of the signal light of 1310 nm at 1 Gbit/s from the 1G-EPON ONU and the signal light of 1270 nm at 10 Gbit/s from the 10G-EPON ONU. The size of the transceiver was reduced by using a tri-port bidirectional optical device (Bi-D) newly developed for 10G-EPON. The external appearance of the Bi-D and the block diagram of the optical transceiver are shown in Fig. 3 (a) and (b), respectively. By using an improved heat dissipation method from the Bi-D accommodated in the transceiver, the optical transceiver in this configuration can operate over a wide case temperature range of -30°C to 80°C and achieves a

low power consumption satisfying the standard power consumption class 3 (3.5 W or less) of the XFP specification while being equipped with a high-output transmitter with 1 Gbit/s and 10 Gbit/s. Figure 4 shows the relationship between power consumption and case temperature for a typical sample.

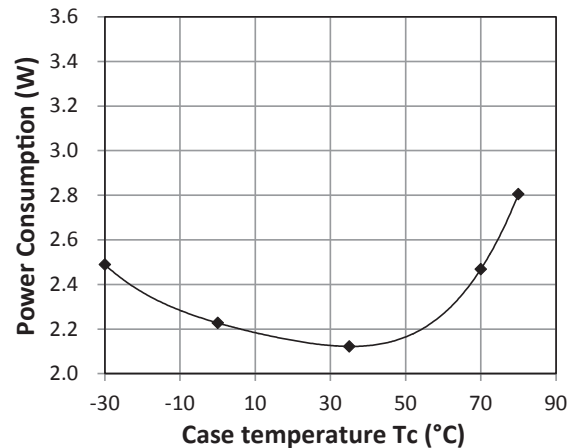

Fig 4. Power consumption of the transceiver

3-2 Reducing operational expenditure

This section describes our approach to the social demand for reducing operational expenditure. In the case of 10G-EPON OLT, the line accommodation and concentration functions, which used to be in multiple separated equipment, were integrated into a single OLT, thus saving space and power consumption per subscriber.

(1) Space saving

The size of components used in the OLT was aggressively reduced and other efforts, such as increasing the degree of integration by improving the layout, were also made. Consequently, the volume of the OLT necessary per subscriber was reduced to less than a third as compared to our 1G-EPON OLT (Table 2). In addition, the line concentration function was integrated into the OLT and therefore, taking the space for the line concentration function into account, even more space was saved. The number of subscribers per OLT was significantly increased from that of 1G-EPON OLT.

(2) Power consumption saving

For the 10G-EPON OLT, highly-integrated semiconductors were aggressively used mainly to improve the efficiency of the power supply. In addition, since the line concentration function was integrated into the OLT, the power consumption of the OLT per subscriber was reduced

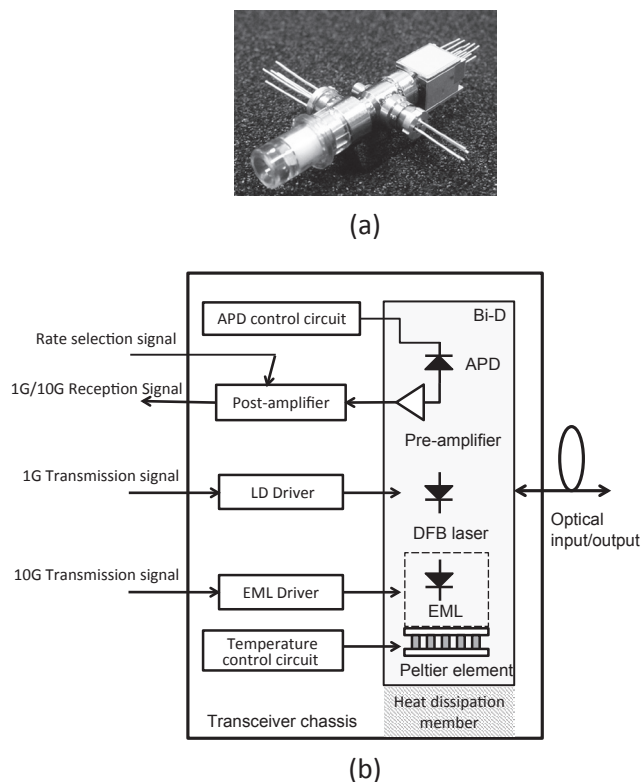

Fig 3. (a) External appearance of Bi-D
(b) Block diagram of the optical transceiver for OLT

Table 2. Relative comparison of 1G-EPON and 10G-EPON OLTs

	1G-EPON	10G-EPON
Line concentration function	Externally installed	Built-in
Volume per subscriber	1	0.28
Power consumption per subscriber	1	0.63

to about 60% as compared to 1G-EPON OLT, provided that the number of subscribers accommodated was the same (Table 2). The power consumption was estimated from References.⁽⁷⁾

3-3 Improving OLT reliability

For a 10G-EPON OLT that accommodates many subscribers, the structure should be able to continue services for subscribers even in the event of a failure that affects the whole line concentration section and in the case of maintenance work, such as updating the firmware in the line concentration section. Accordingly, the doubled line concentration sections are required as redundancy. In normal times, both of the line concentration sections are activated and the data traffic of the subscribers accommodated is relayed in a load-sharing manner, whereas if one of the line concentration sections gets unable to continue services for subscribers due to a failure, the function is degenerated and transferred to the other to make it possible to continually relay the traffic of all subscribers accommodated (Fig. 5). Since the line concentration section can be forcibly degenerated or restored using the maintenance command, maintenance work, such as software update, can be performed without suspending services, thus improving convenience.

The connection between the line concentration section and core network equipment is established by using link aggregation (LAG^{*5}) at the uplink port. By logically aggregating an uplink port of each line concentration section, the LAG is configured so that even if data communication is lost at one port due to a failure or maintenance work such as optical cable replacement, data communication is degenerated and transferred to another port of the LAG, allowing

data communication to continue. Since the uplink port can also be forcibly degenerated and restored using the maintenance command, convenience during maintenance work is improved.

A common interface can be used to operate the line concentration section and degenerate and restore the uplink port using the LAG. This function is used mutually with our optical network products and realized on sOFIA, which is a software platform with a solid track record of operation. Our sOFIA absorbs differences in hardware that varies for each product and provides various functions with common interfaces and functions. This enables development by utilizing the assets we have developed to date and ensures reliability by reducing the risk of software quality degradation in large-scale software development.

4. Conclusion

We have developed an OLT that supports 10G-EPON. Space and power consumption were reduced by integrating the line concentration function while ensuring compatibility with the existing 1G-EPON. In addition, fault tolerance was improved by providing the line concentration section and the uplink port with redundancy, and reliability was improved by adopting a common platform.

Higher access line speed using 10G-EPON will allow high-definition video broadcasting and other new services based on broadband communication, which is expected to contribute to even higher speed and more diverse network services in Japan and abroad.

- sOFIA is a trademark or registered trademark of Sumitomo Electric Industries, Ltd.
- IEEE is a trademark or registered trademark of the Institute of Electrical and Electronics Engineers, Inc.

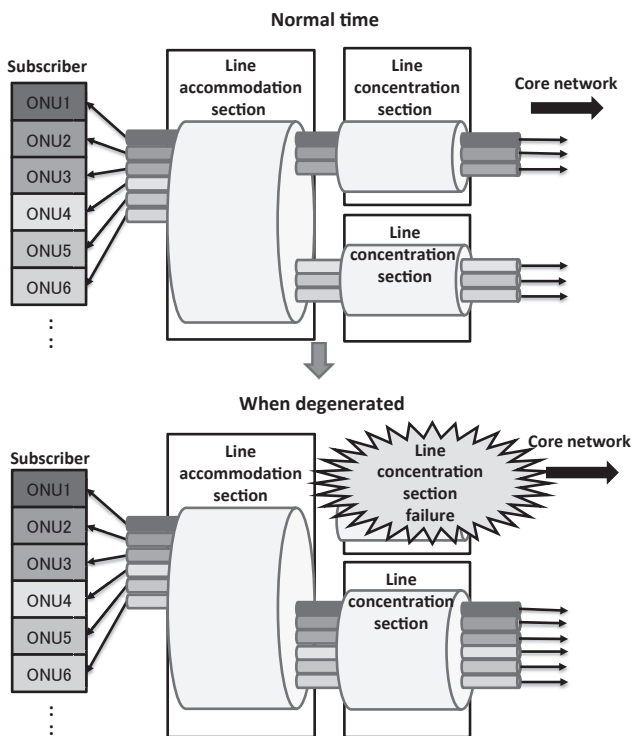

Fig 5. Degeneration operation of the line concentration section

Technical Terms

- *1 EPON: One of the systems used for FTTH, whereby data are exchanged using the Ethernet frame format. EPON consists of an optical line terminal and multiple optical network units, and multiple users can communicate over a single optical fiber. According to the standard, the maximum communication speed is 1 Gbit/s for 1G-EPON and 10 Gbit/s for 10G-EPON.
- *2 Wavelength division multiplexing (WDM): A system whereby multiple users simultaneously communicate using the respective different frequency bands in a single optical fiber.
- *3 Time division multiplexing (TDM): A communication system whereby multiple users are allocated their respective transmittable periods and share a single optical fiber for communication.
- *4 Multi-point control protocol (MPCP): A mechanism to achieve efficient upstream communication (in the direction from the optical network units to the optical line terminal) in the section where a single optical line terminal is point-to-multipoint connected to optical network units.
- *5 Link aggregation (LAG): A mechanism to bundle multiple lines so that they can be handled as a single line. Since multiple lines can be used simultaneously, the communication bandwidth can be expanded. In addition, LAG offers excellent fault tolerance because communication can be continued even in the case of a fault in one of the multiple lines.

References

- (1) The press Release of Ministry of Internal Affairs and Communications, "Aggregation and Provisional Calculation of Internet Traffic in Japan, Announcement of aggregate results as of November" (Feb. 7 2017)
- (2) The press Release of Ministry of Internal Affairs and Communications, "Announcement of Quarterly Data on the Number of Telecommunications Service Subscriptions and Market Share (FY2016 Q3 (End of December))" (Mar.21 2017)
- (3) Yusuke Kai, and etc., "10G-EPON System Featuring High-Speed and High Capacity Layer 3 Switching," SEI Technical Review, No.83 (October 2016)
- (4) LAN/MAN Standards Committee of the IEEE Computer Society, "IEEE Standard for Ethernet (IEEE Std 802.3-2015)" (3 September 2015)
- (5) SFF Committee, "INF-8077i 10 Gigabit Small Form Factor Pluggable Module," Revision 4.5 (August 2005)
- (6) Tomoyuki Funada, and etc., "Development of Small Optical Transceiver for 10G-EPON," SEI Technical Review, No75 (October 2012)
- (7) Hiroataka Ujikawa, and etc., "Issues and Solutions in Saving Energy of Optical Access Network Equipment," NTT Technical Review, Vol.13 No.3 (2015)

Contributors

The lead author is indicated by an asterisk (*).

H. SHIMIZU*

• Assistant General Manager, Information Network R&D Center



T. FUNADA

• Senior Assistant Manager, Information Network R&D Center



M. DAIMA

• Senior Assistant Manager, Information Network R&D Center



H. TAKAHASHI

• Group Manager, Broad Networks Division



N. YOSHITANI

• Assistant Manager, Broad Networks Division

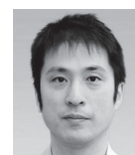

H. MURATA

• Deputy General Manager, Information Network R&D Center

