Sumitomo Fiber Specification

SE-5**

PureBand™ Single-Mode Fiber

*Zero Water Peak (ZWP) Attenuation Optical Fiber,
ITU G.652D
TIA Type IVa*

Issued: March 2009



78 Alexander Drive, Research Triangle Park, NC 27709
Phone (919) 541-8100, Fax (919) 541-8265
www.sumitomoelectric.com

CONTENTS

1. GENERAL.....	2
1.1 FIBER DESCRIPTION	2
1.2 QUALITY	2
1.3 RELIABILITY	2
2. FIBER DESIGN.....	3
2.1 GENERAL.....	3
2.2 CONSTRUCTION	3
3. FIBER CHARACTERISTICS.....	4
3.1 OPTICAL CHARACTERISTICS	4
3.2 MECHANICAL CHARACTERISTICS.....	5
4. TESTING AND INSPECTION	5
5. INSTALLATION / HANDLING PRACTICES	5
6. ORDERING INFORMATION.....	5

1. General

This specification covers the design requirements and performance standards for the optical fiber described below. This fiber is used in Sumitomo's optical cables. The features described in this document are intended to provide information on the performance of Sumitomo Electric's optical fiber and aid in handling and use. Refer to the appropriate *cable* specification for details regarding the finished cable's performance.

1.1 Fiber Description

Sumitomo's PureBand™ single-mode optical fiber is a zero water peak, step index dispersion unshifted fiber with a glass core, glass cladding and dual acrylate protective coatings, and is compliant with ITU G.652D. This Type IVa TIA specified fiber is optimized for operation in 5 operating windows between 1285 to 1625. It is fully compatible with commercially available splicing and connector products and can be spliced to other commercially available single-mode fibers.

Zero water peak single-mode fiber is ideal for WDM use in Access or Metro Network. The PureBand single-mode fiber used in Sumitomo's cables meets all Telcordia requirements.

1.2 Quality

Sumitomo ensures a high level of quality through ISO / TL 9000 registered Quality Management Systems and our commitment to continuous improvement. Guaranteed, high quality products have been manufactured at Sumitomo's facility in Research Triangle Park, North Carolina since 1984.

1.3 Reliability

Sumitomo ensures product reliability through rigorous qualification testing of each product family to meet or exceed industry standards. Both initial and periodic qualification testing are performed to assure the fiber's performance and durability in the field environment.

Sumitomo supports industry standards organizations such as Bell Communications Research (Telcordia), Telecommunications Industry Association (TIA), International Telecommunications Union (ITU), International Electrotechnical Commission (IEC), American Society for Testing and Materials (ASTM), Rural Utilities Service (RUS), The Institute of Electrical and Electronics Engineers (IEEE), and Insulated Cable Engineers Association (ICEA).

2. Fiber Design

2.1 General

Sumitomo employs only the highest quality, zero water peak, single-mode fibers in their cables. The step index glass fibers are coated with dual acrylate protective coatings to provide the necessary bending and tensile strength required for handling in the field and to ensure maximum fiber lifetime through increased reliability. Colored ink coatings are applied per the detailed cable specification.

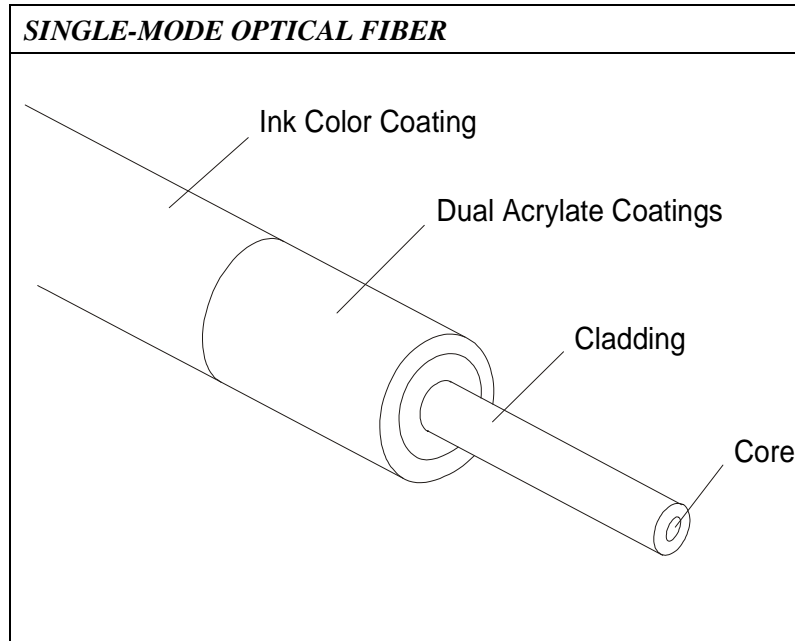

2.2 Construction

<i>SINGLE-MODE OPTICAL FIBER</i>			
FIBER REGION	PROPERTY	TEST PROCEDURE	SPECIFICATION
Core (Glass)	Core/Cladding Offset	EIA/TIA-455-176	$\leq 0.4 \mu\text{m}$
Cladding (Glass)	Diameter	EIA/TIA-455-176	$125 \pm 0.5 \mu\text{m}$
	Non-Circularity	EIA/TIA-455-176	$\leq 0.5 \%$
Coating	Material		UV-Acrylate
	Inked Diameter	EIA/TIA-455-173	$250 \pm 15 \mu\text{m}$

3. Fiber Characteristics

3.1 Optical Characteristics

<i>SINGLE-MODE OPTICAL FIBER</i>			
PROPERTY		TEST PROCEDURE	SPECIFICATION
Maximum Individual Fiber Attenuation (Uncabled)	At 1310 nm At 1383 nm At 1550 nm At 1625 nm	EIA/TIA-455-61	≤0.33 dB/km ≤0.31 dB/km ≤0.19 dB/km ≤0.22 dB/km
Point Discontinuities at 1310 / 1550 nm		EIA/TIA-455-59	≤ 0.05 dB
Water Peak Stability at 1383 nm		EIA/TIA-455-78	≤ 0.31 dB/km
Attenuation Change vs. Bending	100 wraps / 60 mm dia. (1625) 100 wraps/ 50 mm dia.(1310/1550nm) 1 wrap / 32 mm dia.(1550nm)	EIA/TIA-455-62	≤ 0.05 dB ≤ 0.05 dB ≤ 0.05 dB
Chromatic Dispersion at 1550 nm 1625 nm		EIA/TIA-455-168	≤ 18.0 ps/nm·km ≤ 22.0 ps/nm·km
Zero Dispersion Wavelength		EIA/TIA-455-168	1302 - 1322 nm
Zero Dispersion Slope		EIA/TIA-455-168	≤ 0.090 ps/nm ² ·km
Nominal Mode Field Diameter	1310 nm	EIA/TIA-455-167	9.20 μm
Mode Field Diameter Tolerance		EIA/TIA-455-167	± 0.40 μm
Cabled Fiber Cutoff Wavelength (λ_{cc})		EIA/TIA-455-170	≤ 1260 nm
Group Index of Refraction	1310 nm 1550 nm 1625 nm	EIA/TIA-455-44	1.466 1.467 1.470
Polarization Mode Dispersion	Uncabled Fiber PMD Link Design Value		< 0.2 ps/√km <0.08ps/√km

Note: PureBand fiber specification supports network design requirements for a 0.20 ps/√km of maximum PMD link design value specified by ITU-T G.652D.

3.2 Mechanical Characteristics

<i>SINGLE-MODE OPTICAL FIBER</i>		
PROPERTY	TEST PROCEDURE	SPECIFICATION
Proof Test Stress	EIA/TIA-455-31	120 kpsi (0.86 GPa)
Fiber Curl Radius	EIA/TIA-455-111	≥ 4 meters
Minimum Bend Radius:	During Installation	16.0 mm
	During Service	30.0 mm

4. Testing and Inspection

The optical properties of all fibers are measured prior to cable manufacturing and remain traceable throughout the manufacturing process and the lifetime of the cable.

After cabling, we use statistical process control techniques along with periodic verification to insure 100% compliance to attenuation requirements in each length of cable with bi-directional OTDR at all operating wavelengths. Cable dimensional measurements are also made at final inspection and recorded.

5. Installation / Handling Practices

Sumitomo has incorporated a wide range of technical support and training services for our fiber optic cable products into our Technical Support Services (TSS) program. TSS offers training in the areas of cable installation sheath entry, splicing, testing, and system troubleshooting. The services are available in a variety of media formats and can be customized to better accommodate individual training needs. The TSS program consists of an extensive series of recommended procedure documents, training courses with classroom and hands-on instruction, as well as demonstration video tapes. Please contact Sumitomo's Customer Service department for more information.

6. Ordering Information

To learn more about Sumitomo's cables or to place an order, call, fax, e-mail, or write us at:

*Sumitomo Electric Lightwave Corp.
78 Alexander Drive
Research Triangle Park, NC 27709
Attn: Customer Service Department*

*Phone: 800-358-7378
919-541-8100
Fax: 919-541-8265
E-mail: info@sumitomoelectric.com*

Sumitomo Electric Lightwave Corp. reserves the right to improve, enhance, or modify the cable's features and specifications. For special requirements different than those shown above, please contact our Inside Sales Department. Each Sumitomo Electric Lightwave Corp. optic cable and/or its manufacture may be covered by one or more of the following US Patents: 4,715,677 4,729,629 4,763,983 4,770,489 4,828,349 4,953,945 5,043,037 5,082,347 5,165,003 D331,567 5,247,599 5,410,901 5,471,555 5,642,452. Cable and/or its manufacture may be covered by one or more of the following US Patents: 4,715,677 4,729,629 4,763,983 4,770,489 4,828,349 4,953,945 5,043,037 5,082,347 5,165,003 D331,567 5,247,599 5,410,901 5,471,555 5,642,452.