

Diamond-like Carbon Film for Bearing Parts and Its Mass Production Technology

Yoshikazu TANAKA*, Koji MIYAKE, and Atsushi SAITO

Active efforts have been made to create environmentally friendly products in the automobile market. Under this circumstance, parts that make up an automobile need to maintain their functions in harsh environments, requiring even higher durability than ever before. To meet this challenge, we have developed a diamond-like carbon (DLC) film that has an excellent rolling fatigue resistance for bearing parts. We also started the mass production of the DLC film coating for bearing parts by overcoming production technology challenges, and achieved both mass productivity and cost efficiency.

Keywords: DLC, Bearing parts, Compressor, CO₂ refrigerant

1. Introduction

The development of electric vehicles, hybrid electric vehicles, and fuel cell vehicles is actively underway in the automobile industry as one countermeasure for global warming and fossil fuel depletion. In electric-based vehicles, components such as the motor, gearing, and bearing parts are exposed to different types of sliding movements from those in conventional engines. Among such components, Nippon ITF Inc. has focused on bearing parts. Regardless of the type of power supply, a vehicle contains a large number of bearing parts in its system, and these bearing parts are required to maintain low friction for operational efficiency and energy-saving purposes. These parts must also be more durable as their size and weight are reduced or as the oil becomes less viscous.

Nippon ITF chose a roller bearing among the various bearing parts, and aimed to improve its durability by creating a new type of coating.

2. Overview of DLC Coatings

Diamond-like carbon (DLC) coatings is the general name for thin-layer coatings that have a carbon-based amorphous (non-crystalline) structure. DLCs have both diamond (sp^3 -bonded carbon formations) and graphite (sp^2 -bonded carbon formations) in their overall structure

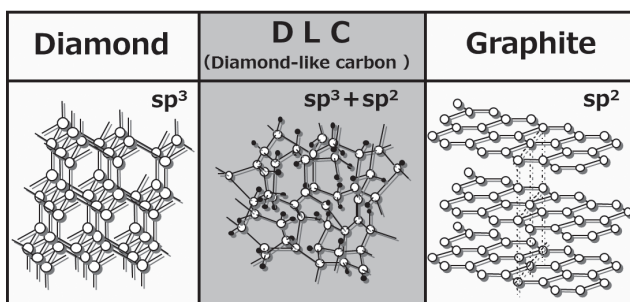

Fig. 1. Structural comparison of diamond, DLC, and graphite

(Fig. 1).

The physical properties (characteristics as a material) of DLC coatings are determined by the ratio between sp^3 and sp^2 formations, the percentage of hydrogen content within the structure, and by other metallic elements and their percentages within the material. Figure 2 shows the ternary phase diagram of amorphous carbons presented by C. Ferrari and J. Robertson to explain the conceptual structure of DLCs.⁽¹⁾

Hydrogen-free DLCs can be classified into tetrahedral amorphous carbon (ta-C) and amorphous carbon (a-C), depending on the ratio of sp^3 and sp^2 formations. ta-C is more commonly used in DLC coatings because its high degree of hardness is preferred for industrial use. In addition to having a high degree of hardness and thermal durability, the ta-C DLC coating possesses excellent capabilities to reduce the friction coefficient in an oil. For this reason, ta-C DLC coatings are highly rated as one of the most efficient surface treatment methods for products exposed to car engine oil. Hydrogenated DLCs can be categorized as hydrogenated tetrahedral amorphous carbon (ta-C:H) and hydrogenated amorphous carbon (a-C:H). Hydrogenated DLCs feature the capability to significantly reduce the friction coefficient in an unlubricated environment.

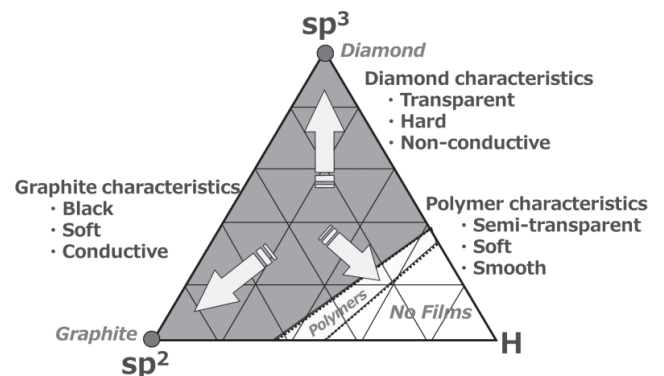

Fig. 2. Characteristic diagram of a DLC

Based on these characteristics, the optimum DLC coating structure for the target product must be selected and designed.

3. Creating a DLC Coating

Table 1 shows the typical production methods for DLC coatings.

Table 1. Production methods and materials for DLC coatings

| Coating | Production method | Materials |
|---------------|--|-----------------------------------|
| a-C:H | Plasma-enhanced chemical vapor deposition Ionized deposition Plasma-based ion implantation | Hydrocarbon gas |
| ta-C, a-C | Arc ion plating Laser ablation | Solid graphite |
| a-C, a-C:H | Sputtering Unbalanced magnetron sputtering | Solid graphite Hydrocarbon gas |

An a-C:H DLC coating is produced from a hydrocarbon gas, such as methane and acetylene, using plasma-enhanced chemical vapor deposition (CVD),*¹ ionized deposition, and plasma-based ion implantation. When using solid graphite as a material with arc ion plating and laser ablation, a ta-C or an a-C DLC coating is produced. If solid graphite is used as the material with sputtering or unbalanced magnetron (UBM) sputtering, an a-C DLC coating is produced. Finally, when solid graphite and hydrocarbon gas are used as the materials, plasma-enhanced CVD is also used in addition to the above production methods, producing an a-C:H DLC coating. Thus, a variety of DLC coatings can be produced depending on the production method and materials used, with the DLC coating's physical properties greatly varying accordingly.

4. Role of DLC Coatings on Roller Bearing Parts

Common types of damage that can occur on roller bearing parts include flaking, peeling, seizure, and chipping. One of the causes of flaking and peeling is the weakening of the superficial layer of the product due to the invasion of hydrogen generated by the degradation of the lubricating oil. The application of a DLC coating to the surface of the product is reported to be able to prevent this hydrogen invasion (Photo 1).^{(2),(3)} Nippon ITF has focused

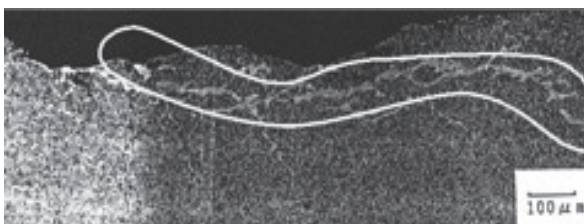

Photo 1. Weakening of the metal surface due to white etching

on this capability. However, to obtain sufficient hydrogen invasion prevention, durability against DLC coating peeling due to rolling contact fatigue must be improved.

5. Optimum DLC Coating for Roller Bearing Parts

The optimum performance required for the DLC coating for roller bearing parts must include smooth surface and low friction, low aggressiveness to adjacent components, and high durability against peeling from roller contact fatigue, as mentioned above. Nippon ITF first assessed the peeling durability of the DLC coating against roller contact fatigue utilizing the test machine that models a bearing as shown in Fig. 3. The first sample used for the assessment was an HT-DLC coating made using a conventional CVD method that provides a smooth surface with less aggressiveness to adjacent parts. This sample did not have sufficient peeling durability due to low bonding to the metal primer that adheres the DLC coating to the base material. The second sample was an HA-DLC coating made using the physical vapor deposition (PVD) method.*² The peeling durability of the second sample was better than the first sample, however, the hardness of the coating proved excessive in the ball-on-disk test. This test was to assess the wear on a DLC coated disc and an SUJ2 ball from the contact between the two. The result was that damage to the ball by the second sample was greater than the first sample due to the hardness of the DLC coating.

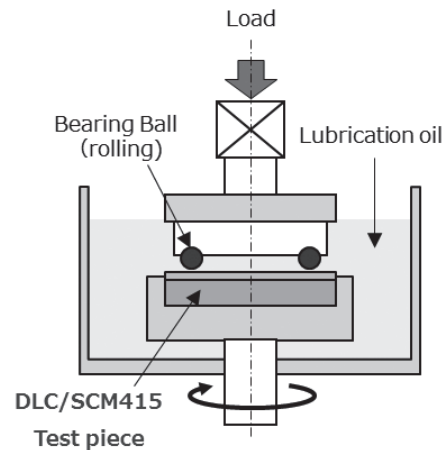

Fig. 3. Thrust testing machine diagram

Nippon ITF undertook further studies in order to create a DLC coating highly durable against rolling contact fatigue by utilizing the features of both the HT- and HA-DLC. The layering made using the CVD method has low ionization in the base to medium layers: hence, the adherence of the DLC coating is low. We successfully increased the adherence of the coating to the base material by applying our exclusive method to increase ionization in the base to middle layers during the coating formation. In

this way, we developed a DLC coating (Genius Coat HS; hereafter, “HS Coating”) that could realize high fatigue durability sufficient for a bearing part, while benefitting from the low-aggressiveness of the CVD-made DLC (Figs. 4 and 5).



| | Genius Coat HS | Genius Coat HA | Genius Coat HT |
|---------------------|---|--|--|
| 225K times fatigue | No peeling  | No peeling  | Partially peeled  |
| 1.26M times fatigue | No peeling  | Peeled all around  | Peeled all around  |

Fig. 4. Results of rolling contact fatigue test on different DLC coatings

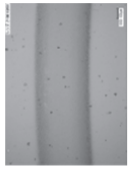
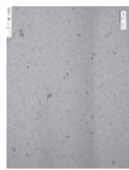
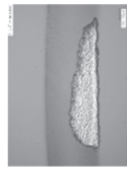
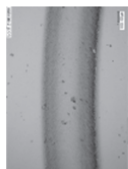
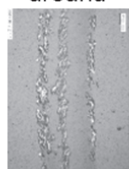
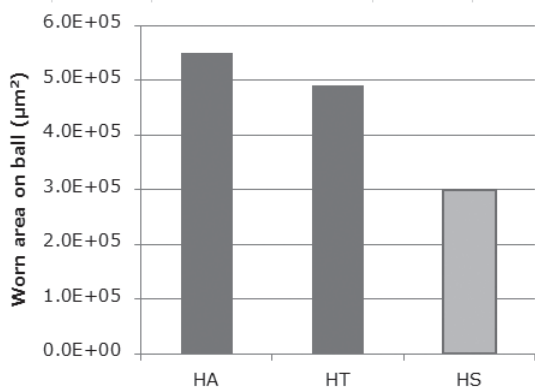
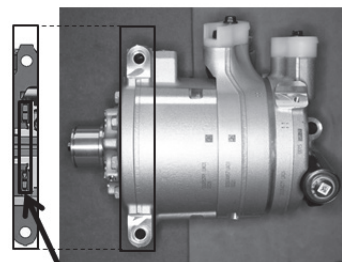

Fig. 5. Aggressiveness assessment of different DLC coatings using ball-on-disk test

6. Application of DLC Coating to Bearing Parts

To realize a commercial application of the developed DLC coating, we made a prototype bearing part for an air conditioner compressor produced by Toyota Industries Corporation. An air conditioning system requires a refrigerant, such as a hydrofluorocarbon (HFC). The compressor in which our prototype was incorporated, uses CO₂ as the refrigerant because it has an extremely low global warming potential (GWP).⁽⁴⁾ Using CO₂ as a refrigerant requires a higher compression pressure compared with an HFC refrigerant; therefore, the temperature also rises, placing a higher load on the compressor as a whole. Among the compressor

components, bearing parts in particular have to function in extremely high friction conditions. This is the reason we decided to apply our DLC coating to the bearing parts since the coating has high sliding capability in this high friction environment. We started to explore the optimum characteristics for the HS Coating, such as coating thickness and quality and surface status, to be applied to the roller of the bearing part. Eventually, we developed a coating that could deliver a sufficiently high peeling durability to satisfy the requirements for the roller (Fig. 6 and Photo 2). The mass application of this coating to rollers started in 2017.



DLC-coated bearing adopted here

Fig. 6. Compressor appearance and DLC-coated part

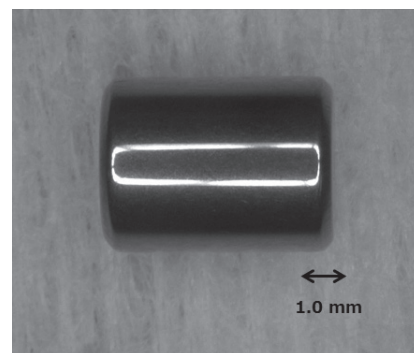

Photo 2. Roller appearance

7. Application of DLC Coating to Bearing Parts

We identified the following issues concerning applying a DLC coating to a roller on a commercial production scale. We established and refined solutions for these issues before reaching the actual production stage.

7-1 Mass application of DLC coating

The first issue was applying the DLC coating to a large number of small rollers at the same time. We tailored the shape of the fixtures used to coat the rollers and optimized the arrangement of the rollers to be coated to secure evenness of the DLC coating on a mass production scale (Figs. 7 and 8).

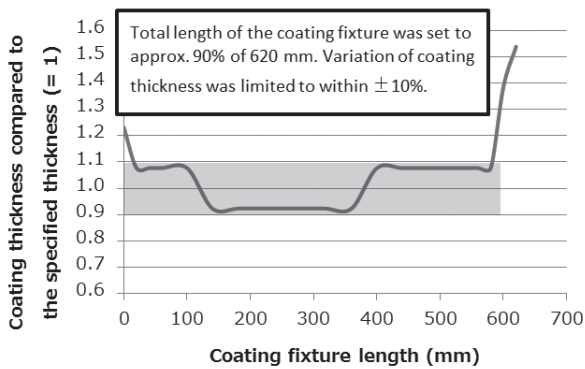

Fig. 7. Coating thickness distribution along the coating fixture

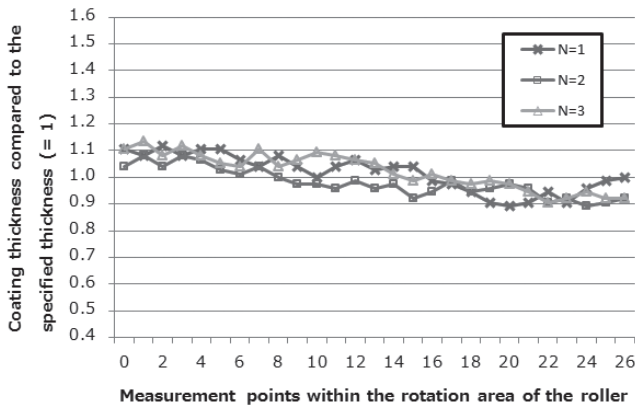

Fig. 8. Coating thickness distribution within a single roller (tested with N=3)

7-2 Roller surface improvement (removing droplets)

When applying an HS Coating to a roller, tiny projections, called “droplets,” are generated on the coating surface. When a roller with droplets rotates inside a bearing, these droplets are broken and the broken droplets can damage the roller itself or adjacent parts. To remove such droplets on the HS Coating, we used barrel polishing. This smoothed the roller surface avoiding the problem of such damage (Fig. 9).

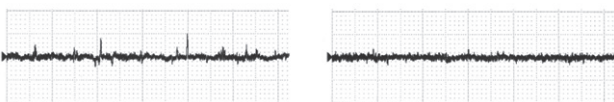

Fig. 9. Roller surface roughness before (left) and after polishing (right)

7-3 Quality assurance of fatigue durability (adherence)

Coating quality can be assessed by observing the peeling around an indentation caused by a Rockwell hardness test. However, we found that this method is insufficient to accurately assess the coating adherence in terms of rolling fatigue durability required for rollers. We assumed

that the best assessment method would be to simulate the actual operating environment of the bearing, and we established a standalone acceleration testing environment, in which several coated rollers are installed in a bearing and then actually rotated (Fig. 10). The test conducted in this environment enabled us to confirm the correlation between the coating performance within an actual roller bearing and the adherence quality. This became our established method to assess adherence in terms of rolling fatigue durability.

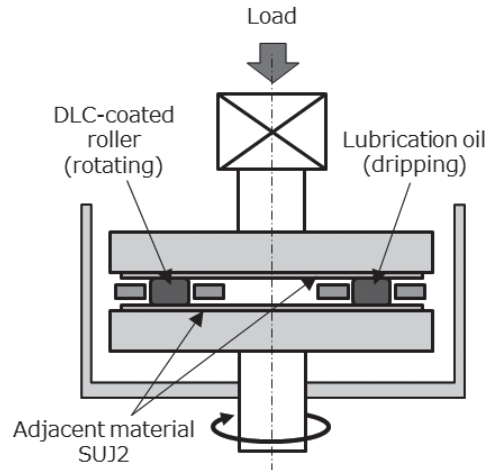

Fig. 10. Overview of standalone testing machine

7-4 Creating an automatic visual inspection system

Visual inspection of the entire finished surface of each roller, which is small and in high numbers, makes demands on human eyes, takes time and results in quality fluctuation. This fact may also compromise the quality of such an inspection. Therefore, we planned to establish an automatic visual inspection system as one of the key components for the mass application of the DLC coating to the rollers. Since the entire lateral surface, top surface, and base surface of each roller must be inspected, we needed to refine the position of the cameras, lighting, and conveyer system to achieve a thorough inspection. Also, the settings of the cameras and lighting were optimized to correctly detect various types of defects on the rollers. In this way, an automatic visual inspection system, with high accuracy, was eventually realized (Photos 3 and 4).

7-5 Further improvement of productivity

We have enhanced our current DLC coating system—the Batch Processing Multi Arc PVD System (model M720)—into a larger model with higher specifications, the iDS1000 (Photos 4 and 5). The more efficient roller arrangement inside the iDS1000 will enable the production capability to be increased by up to five times that of current production volumes. The coating time will also be shortened by 20 to 30% by the new mechanism incorporated in the iDS1000.



Photo 3. Automatic visual inspection system

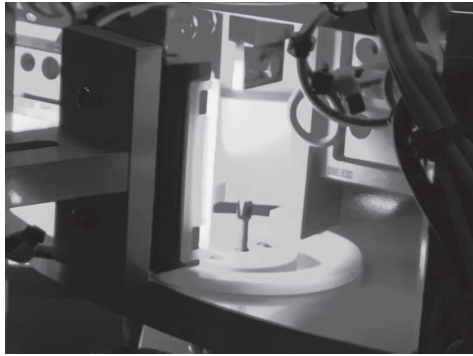

Photo 4. Inspection compartment of the automatic visual inspection system

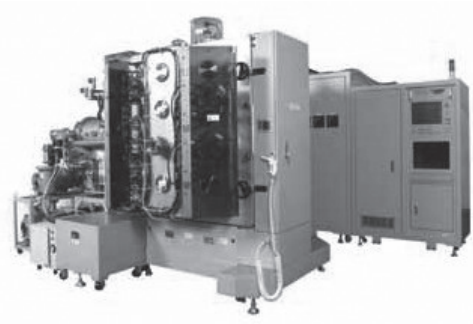

Photo 5. M720 coating system

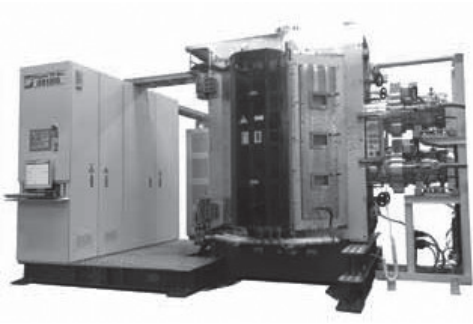

Photo 6. iDS1000 coating system

8. Conclusion

We developed a DLC coating optimized for roller bearing parts and the coating was successfully adopted in a commercial application to a bearing part in a CO₂ compressor manufactured by Toyota Industries Corporation. We will work for advanced quality improvement of the coating and cost reduction with the aim of applying it to various bearing parts and supporting mass processing of small components.

9. Acknowledgements

This development was achieved with the cooperation of Toyota Industries Corporation. We sincerely thank the company for its help.

Technical Terms

- *1 CVD: A method of depositing a film on a target substrate by a chemical reaction on the substrate surface or gas phase using a source gas containing a film component.
- *2 PVD: A method of physically depositing a film on a target substrate or metal surface by heating the raw material with plasma or laser and evaporating it.

References

- (1) C. Casiraghi, J. Robertson, A. C. Ferrari: Diamond- Like Carbon for Data and Beer Storage, *Materials Today*, 10 (2007) 44
- (2) S. Shiode, R. Lu et al: Tribology conference proceedings of the Japan Tribology Society, 2017-11, C49
- (3) Photo 1 Source Aisin Seiki Co., Ltd. HP
<http://www.aisin.co.jp/pickup/spirits/html/250.html>
- (4) Japan Society of Refrigerating and Air Conditioning Engineers HP
<https://www.jsrae.or.jp/annai/yougo/16.html>

Contributors The lead author is indicated by an asterisk (*).

Y. TANAKA*

• Chief, Nippon ITF, Inc.



K. MIYAKE

• General Manager, Nippon ITF, Inc.



A. SAITO

• Toyota Industries Corporation

