

Wideband High-Power High-Efficiency Amplifiers with GaN HEMTs for Base Station Applications

Akira AKIYAMA*, James WONG, Andrei GREBENNIKOV, Naoki WATANABE, Hiroaki DEGUCHI, and Kaname EBIHARA

Gallium nitride high electron mobility transistors (GaN HEMTs) are characterized by high power, high efficiency, and wideband operation. In recent years, they have gained market share for base station applications. GaN HEMTs are more advantageous for wideband applications than LDMOSs and, therefore, expected to contribute to the establishment of high-power multi-band base stations. This paper presents a packaged GaN HEMT device with internal matching circuits. A high-power wideband asymmetric Doherty amplifier using the devices are also described. The transistor has a pair of 180 W GaN dies. The internal matching circuit is designed with a high-dielectric substrate so that it can be mounted in a compact package while maintaining the wideband characteristics. The asymmetric Doherty amplifier is fabricated using three transistors to cover B1 and B3 LTE bands. It achieves an output power of 59.2 dB and drain efficiency of more than 50% at 8-dB power back-off in the 1.8-2.2 GHz range.

Keywords: GaN HEMT, wideband, high output power, high efficiency, asymmetric Doherty power amplifier

1. Introduction

A high-frequency transistor using gallium nitride (GaN) can deliver a wideband high output power with high efficiency. This transistor is expected to contribute to downsizing, weight reduction, and lower power consumption for the wireless communication infrastructure. In 2000, we commenced research and development of a GaN high electron mobility transistor (HEMT*) on a silicon carbide (SiC) substrate, which offers excellent heat dissipation, and launched mass production of a GaN HEMT in 2006 as a world first. Since then, we have been taking the lead in the GaN HEMT market.⁽¹⁾

When the GaN HEMT was first commercialized, production costs were high and therefore the market was limited. Particularly in the mobile network base station market, a silicon (Si) laterally diffused metal oxide semiconductor (LDMOS) field-effect transistor (FET) has been dominant, due mainly to its low price. However, as demand rose for even smaller and lower power consumption amplifiers, GaN HEMTs, which offer high efficiency, have been gradually employed in base stations, and their share is expanding year by year. Another application where growing demand is expected for GaN HEMTs is multiband base station amplifiers. Conventional base station amplifiers can only support one band per amplifier (Fig. 1), and therefore a multiband base station requires the same number of amplifiers as the number of bands that it supports. On the other hand, the new multiband base station amplifier employs a single wideband amplifier that covers different bands to reduce production and installation costs. The multiband amplifier also provides the flexibility of operation, such as amplifying at a single band with doubled output power (Fig. 2). This is impossible when different amplifiers are used for multiple bands. To create a multiband base station amplifier, a wideband microwave radio frequency (RF) transistor is indispensable. GaN HEMT is more suitable for this purpose than LDMOS FET due to its properties.

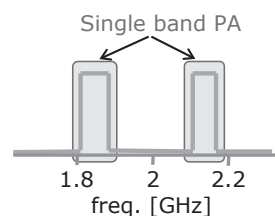

Fig. 1. Single-band amplifiers

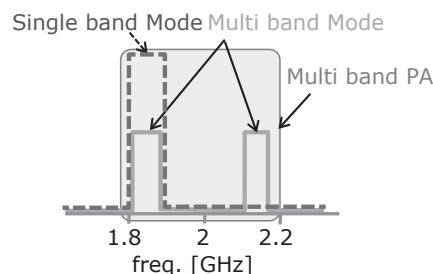

Fig. 2. Multiband amplifiers

In terms of price, GaN HEMT costs are falling thanks to enlarging wafer sizes (from 3-inch to 4-inch) and greater production volumes due to increasing demand. This also accelerates the use of GaN HEMTs in base stations. As several GaN HEMT suppliers are entering into the base station market, and also major LDMOS FET suppliers are now launching new GaN HEMT products,⁽²⁾ the GaN HEMT market is expected to grow further.

This paper reports on a high output power GaN HEMT that we have developed for mobile network base stations, and a wideband high power and highly efficient asymmetric Doherty power amplifier that uses the high power GaN HEMT.

2. Features of GaN HEMT

Table 1 lists the properties of typical materials used in a high power RF transistor.⁽³⁾ Features of our GaN transistor are as follows:

- (1) High voltage operation caused by a wide band gap.
- (2) High current density due to high saturation velocity.
- (3) High thermal conductivity by SiC substrate.

GaN HEMTs have extremely high power density per unit gate width (W_g) due to characteristics (1) and (2), above. Even if the drain-source capacitance (C_{ds}) per W_g is similar to that of LDMOS FETs, the C_{ds} per output power in the GaN HEMTs is much smaller than that in the LDMOS FETs. This means that the loss in the high frequency band is small and that the GaN HEMT can create high-power and high-efficiency RF transistors. Also, its high power density realizes smaller devices than those made using LDMOS FETs with the same output power, which results in higher impedance. This is significantly beneficial in supporting wideband, making the GaN HEMT a superior candidate for use in a high power multiband base station compared to an LDMOS FET. Further, because our GaN HEMT is formed on SiC substrate that has high thermal conductivity, it allows good heat dissipation. This is an advantage in a high power RF transistor in terms of its performance and reliability.

Table 1. Comparison of high power RF transistor materials

Materials	Si	GaAs	SiC	GaN
Band gap energy (eV)	1.1	1.4	3.3	3.4
Critical breakdown field (MV/cm)	0.3	0.4	3.0	3.3
Thermal conductivity (W/cm/K)	1.5	0.5	4.9	2.1
Saturated electron velocity ($\times 10^7$ cm/s)	1.0	2.0	2.0	2.5

 : Applied to our GaN HEMT

3. High Output Power GaN HEMT with Internal Matching Circuits

Figure 3 shows a block diagram of an internal circuit in a GaN HEMT transistor discussed in this paper. A package with two input terminals and two output terminals is used and each path has a 180 W GaN HEMT chip. The ground is common due to its structure, however, the input

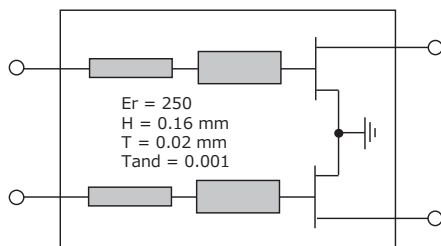

Fig. 3. Internal circuit of the GaN HEMT

and output terminals for each chip are independent.

It is possible to increase the output power of an RF transistor by connecting a number of FET units in parallel and increasing the device size. However, this also increases the gate-source capacitance (C_{gs}), which in turn significantly lowers input impedance. As a result, the input impedance of 180 W class GaN HEMTs becomes less than 1Ω . For such a low impedance, impedance matching with an external circuit is extremely difficult. Thus, a low-loss internal matching circuit is implemented in the package and the impedance is converted to more than 1Ω at the terminal. Also, we use two-stage impedance transformers with a small conversion ratio because the impedance dispersion over frequency should be small to realize wide-band performance. The matching circuit is small enough to mount within a compact package by using high-dielectric substrates. Photo 1 shows an internal view of the transistor. The two-stage impedance transformer is formed with a single substrate and bonding wires. There is no matching circuit for the output side since the output impedance of the GaN HEMT is sufficiently high without the need for an internal matching circuit.

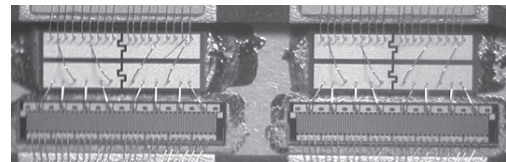

Photo 1. Internal view of the transistor

In this paper, the transistor is regarded as a 360 W transistor by combining two 180 W paths in parallel at the terminals of the package. The load-pull output power and efficiency contour at 1 dB gain compression are shown in Fig. 4. Measurement conditions are $V_d = 50$ V, $I_{dq} = 450$

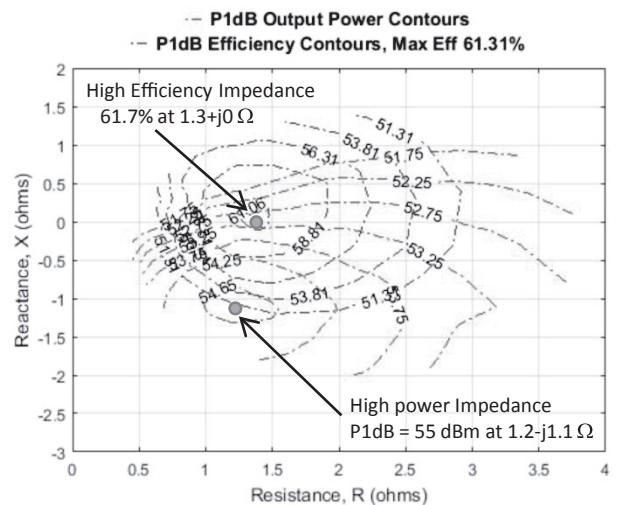

Fig. 4. Load pull measurement result

mA, and frequency = 2 GHz. The maximum output power at 1 dB gain compression reaches 55 dBm at an output load impedance of $(1.2 - j1.1) \Omega$, whereas a maximum efficiency of more than 61% is obtained for a purely resistive impedance of $(1.3 + j0) \Omega$.

4. Doherty Amplifier

Mobile telephone networks use digital modulation techniques to realize high-speed and high-volume data transmission. In this case, the instantaneous output power can exceed the average output power by 6 dB to 10 dB. For this reason, the mobile network base station amplifier has to be highly efficient at the average output power and be capable of delivering the maximum output power that is 6 to 10 dB higher than the average output power. To enhance back-off efficiency, the method called Doherty amplifier is commonly used.

4-1 Symmetric and asymmetric Doherty amplifiers

Figures 5 and 6 represent circuit configurations of a symmetric Doherty amplifier and an asymmetric Doherty amplifier, respectively. Both are realized by connecting in parallel a carrier amplifier that is biased for Class AB operation, and a peaking amplifier biased for Class C operation.^{(4),(5)} In the back-off condition, only the carrier amplifier operates. When high output power is required, the peaking amplifier also works in order to supplement the power insufficiency from the carrier amplifier. The symmetric Doherty amplifier uses a carrier amplifier and a peaking amplifier that have the same output power levels, while the asymmetric Doherty amplifier uses amplifiers with different output power.

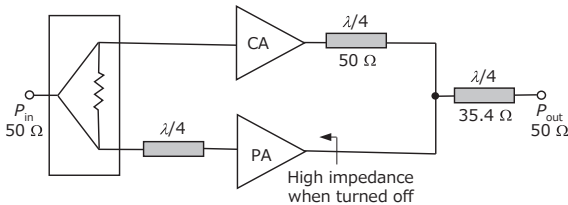

Fig. 5. Symmetric Doherty amplifier

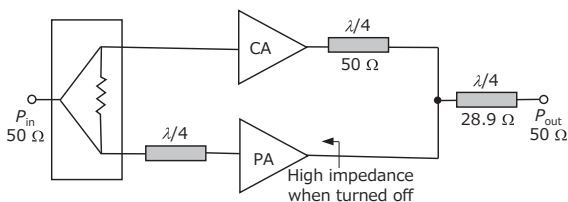

Fig. 6. Asymmetric Doherty amplifier

The efficiency of the Doherty amplifiers and a general Class AB amplifier over output power are shown in Fig. 7. The Class AB amplifier shows the highest efficiency at

saturation, however, its efficiency significantly deteriorates when the back-off level becomes large. On the other hand, a symmetric Doherty amplifier shows the highest efficiency at 6 dB back-off from the saturation. By designing the amplifier average output power level at this point, the highest efficiency is obtained at the average output while allowing a 6 dB buffer for maximum output. For an asymmetric Doherty amplifier, the peaking amplifier output power level is normally set higher than that of a carrier amplifier. This increases the output dynamic range of the back-off points where the highest efficiency is obtained. For example, when the power ratio of the carrier amplifier and the peaking amplifier is designed to be 1:2, the highest efficiency is obtained at a point of 9.5 dB back-off. As data traffic is increasing, a modulation method that allows a larger gap between the peak output and the average output is required. For this reason, an asymmetric Doherty amplifier will be used for the majority of base stations.

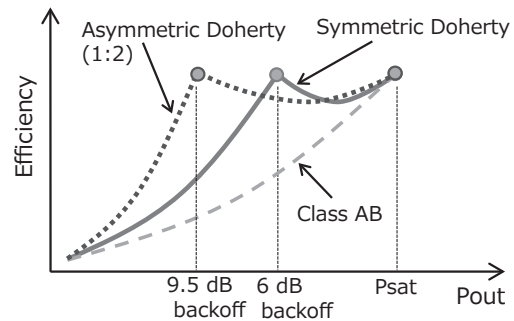

Fig. 7. Efficiency of Doherty amplifiers

4-2 Asymmetric Doherty amplifier with half-wavelength line at the peaking amplifier output

As devices with high output power have lower impedance in general, the width of microstrip lines of external matching circuits becomes large. Also, in order to realize wideband characteristics, impedance conversion ratio need to be small, resulting in an external circuit designed with a low impedance system. In Doherty amplifiers, if wide microstrip lines are used, it can be quite difficult to physically connect the outputs of the peaking amplifier and carrier amplifier. Adding a half-wavelength line at the peaking amplifier output can increase the flexibility of the circuit layout without losing the Doherty operation. To align the phases of the carrier amplifier and peaking amplifier, a $\lambda/4$ length line needs to be incorporated at the input side of the carrier amplifier. An example of this configuration with an asymmetric power ratio of 1:2 is shown in Fig. 8.

4-3 Asymmetric Doherty amplifier with multiple transistors in the peaking amplifier

Doherty amplifiers can be configured with one transistor for the carrier amplifier and two for the peaking amplifiers. Figure 9 is an example of the circuit configuration of the asymmetric Doherty amplifier with multiple peaking transistors converted from Fig. 8. This appears to be similar to three-way Doherty amplifiers, however, it is

clearly different because the two peaking amplifiers in this design have the same configurations and operations, while the two peaking amplifiers in a three-way Doherty amplifier have different matching circuits and operate independently. When the output power ratio between the carrier amplifier and the peaking amplifier is 1:2, output powers of all the transistors become the same. Hence three identical transistors can be used in this configuration.

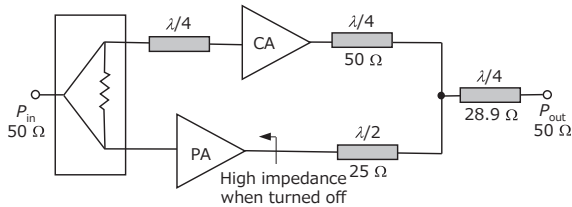

Fig. 8. Asymmetric Doherty amplifier with a half-wavelength line at peaking amplifier output

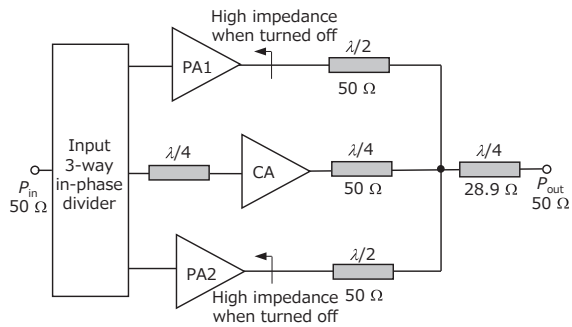

Fig. 9. Example of asymmetric Doherty amplifier design using multiple transistors as peaking amplifiers

Figure 10 shows the test results of a Doherty amplifier made in the above approach. The operating band is the B1

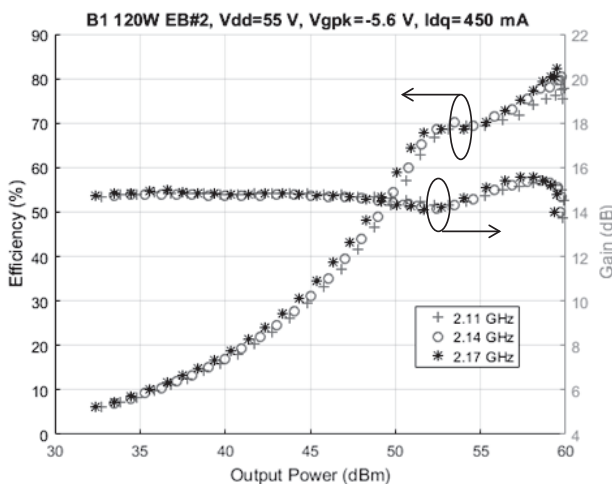

Fig. 10. Characteristics of 2.11-2.17 GHz band Doherty amplifier

LTE band (2.11–2.17 GHz). Three pairs of 2×180 W transistors, as mentioned in Chapter 2, are used. At 55 V operation, 60 dBm (1 kW) of saturated output power, 83% of maximum efficiency, and 15 dB of power gain are observed. In the test of 20 MHz LTE signal (PAR = 9 dB), efficiency as high as 55% is observed at 100 W (at 10 dB back-off) average output power.

5. A 1.8–2.2 GHz Band Doherty Amplifier

A wideband high power asymmetric Doherty amplifier is designed, which supports the B1 and B3 (1.805–1.88 GHz) LTE bands. The circuits are configured with three pairs of 2×180 W transistors in the same way as in the Doherty amplifier described in the previous chapter.

Figure 11 shows a block diagram of the wideband asymmetric Doherty amplifier. To achieve sufficient wideband capability, frequency dispersion of the impedance must be minimized. To realize this, a half-wavelength line is added to the output matching circuit of the carrier amplifier. At the same time, another half-wavelength line is added to the input matching circuit of the peaking amplifier to align the phases of the carrier and peaking paths. The broadband output impedance transformation at 50 Ω output is provided by using a tapered line that has smaller impedance dispersion over a wide frequency range than $\lambda/4$ transformers.

Measured results are shown in Fig. 12. At 55 V, a

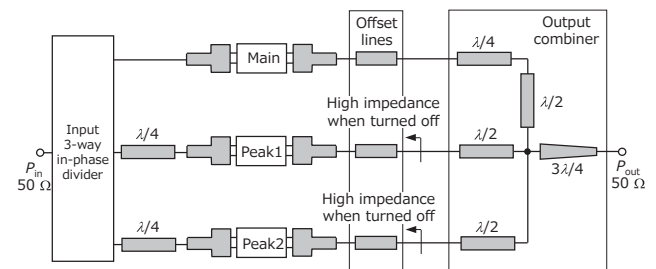

Fig. 11. Configuration of 1.8-2.2 GHz band Doherty amplifier

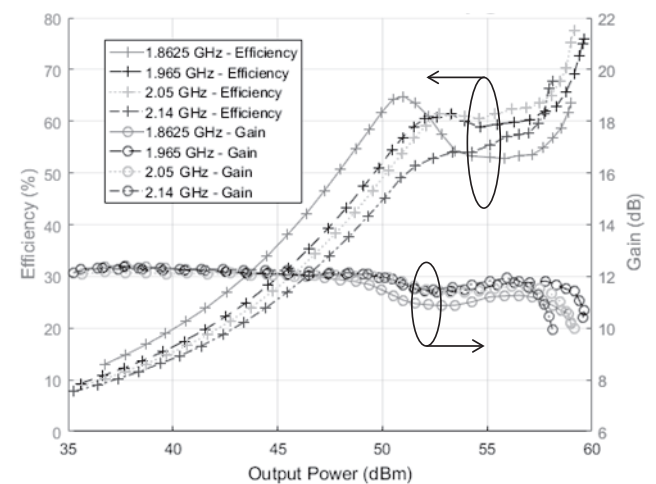

Fig. 12. Performance of 1.8-2.2 GHz band Doherty amplifier

saturated output power of 59.2 dBm and maximum efficiency of 78% with 2 dB gain compression are observed across a majority of the band. At the 8 dB back-off, the efficiency was 50% or higher.

6. Conclusion

This paper introduced high power GaN HEMTs for high-power wideband mobile network base stations and a multiband Doherty amplifier that utilizes these GaN HEMTs. The Doherty amplifier achieves a maximum output power of 59.2 dBm (832 W) and efficiency of 50% or more at 8 dB back-off (with an average output of 132 W). These results indicate that GaN HEMTs are promising for highly efficient high-power multiband amplifiers, which will be highly demanded in the future mobile network base stations.

Although this paper covers solely multiband high-power base stations, GaN HEMTs are also expected to be utilized in next-generation 5G base stations (that use up to 6 GHz and 28 GHz bands) due to their high performance in the high-frequency range.

Technical Term

- *1 High electron mobility transistor: A transistor that utilizes two-dimensional electron induced on a semiconductor junction interface. It can form a high electron density channel less affected by impurity scattering.

References

- (1) H. Sano et al., "A 40W GaN HEMT Doherty Power Amplifier with 48% Efficiency for WiMAX Applications," 2007 IEEE Compound Semiconductor Integrated Circuit Symposium Digest
- (2) URL
<https://www.nxp.com/products/rf/rf-power/rf-power-gan-portfolio:RF-POWER-GAN-PORT>
- (3) K. Takahashi et al., "Wide bandgap semiconductors, optical and electronics devices," Morikita Publishing 2006.
- (4) H. Deguchi, et al., "A 33W GaN HEMT Doherty Power Amplifier with 55% Drain Efficiency for 2.6GHz base stations," 2009 IEEE MTT-S Int. Microwave Symposium Digest
- (5) H. Deguchi et al., "A 2.6GHz Band 537W Peak Power GaN HEMT Asymmetric Doherty Amplifier with 48% Drain Efficiency at 7dB BO," 2012 IEEE MTT-S Int. Microwave Symposium Digest

Contributors

The lead author is indicated by an asterisk (*).

A. AKIYAMA*

- Ph.D.
Manager, Sumitomo Electric Device Innovations, Inc.



J. WONG

- Ph.D.
Sumitomo Electric Europe Ltd.



A. GREBENNIKOV

- Ph.D.
Sumitomo Electric Europe Ltd.



N. WATANABE

- Sumitomo Electric Device Innovations, Inc.



H. DEGUCHI

- Group Manager, Sumitomo Electric Device Innovations, Inc.



K. EBIHARA

- General Manager, Sumitomo Electric Device Innovations, Inc.

